

Adp Laundry

INSTALLATION INSTRUCTIONS

CARE & MAINTENANCE

WARRANTY

- 2 Prior To Installation
- 4 Installation Instructions
- 9 Push-to-Open Door Adjustment
- 10 Door Hinge Alignment & Installation
- 11 Drawer Alignment & Installation
- 14 Care & Maintenance
- 15 Troubleshooting
- 15 ADP Warranty

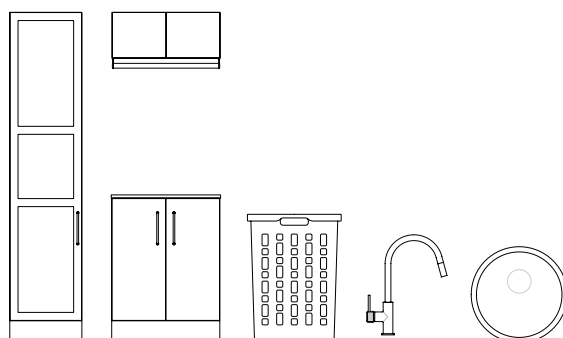

THIS LAUNDRY MUST BE INSTALLED BY A QUALIFIED TRADESPERSON.

Please read the installation instructions BEFORE INSTALLATION.

If the product is not installed in accordance with these instructions, your ADP warranty may be void and the homeowner may have a claim against you (the installer).



IMPORTANT - It is the responsibility of the installer to make any adjustments to doors/drawers after installation if required.

There may have been some movement in transportation and installation which causes doors/drawers to become unaligned.

PLEASE RETURN TO HOME OWNER - IMPORTANT CARE & WARRANTY INFORMATION INSIDE.

For more information visit www.adpaustralia.com.au.

✓ PRIOR TO INSTALLATION CHECKLIST



This product must be installed by a qualified tradesperson and we would expect the installation to be undertaken in a tradesperson like manner and finished to a tradesperson standard. This product carries a full warranty against faulty workmanship and materials.

Please inspect thoroughly before installation to ensure that the product has not been damaged and is correct. No claims for damage or incorrect items will be recognised once installation has begun.

IT IS THE RESPONSIBILITY OF THE INSTALLER TO MAKE ANY ADJUSTMENTS TO DOORS/DRAWERS AFTER INSTALLATION IF REQUIRED.

1 CHECK PRODUCTS FOR ANY DAMAGES

Within 48 hours of receiving your goods, unpack your ADP product and check for any possible freight damages or incorrect items. *Please contact your place of purchase to report damages or missing parts.*

Check you received a hardware bag and take note of tools and any other supplies you may need before starting installation.

Note: you will need to supply your own appropriate wall fixing screws.

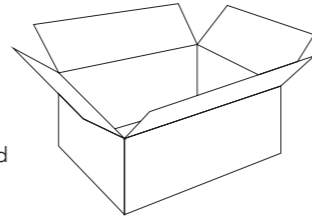

No claims for damages will be recognised once installation has begun.

2 LOCATE SUPPORT BEAMS

You will need to locate your stud positions throughout the wall, take note of this so you are aware of these positions when you cover them up with the tall units.

All cabinets will need to be attached to the wall using a minimum of 8 gauge 60mm screws if you have a stud wall.

If your wall is brick, concrete or another surface ask your hardware specialist for advice on the right fixing methods.

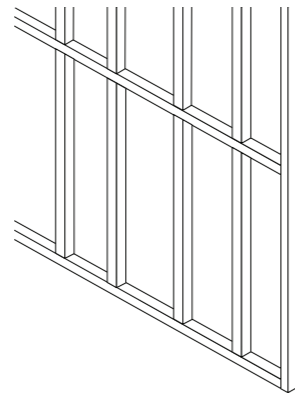

3 CHECK FOR PLUMB WALLS & LEVEL FLOORS

If you fix the product to a non-plumb wall or floor the following could happen:

- Your door or drawers will not operate correctly.
- Doors or drawers will not align.

If it is not possible to make the wall plumb and straight you must pack the wall cabinets out so that it does not follow the out of aligned wall before fastening.

Floor standing cabinets must sit on a level floor or adjust plastic feet so they sit level and true before fastening to wall.

PLEASE NOTE

We recommend using the supplied 28mm screws to join all adjoining floor and tall cabinets together and all adjoining wall cabinets together before fixing the cabinets to the wall. This will help with easier cabinet installation and overall levelling. Don't forget to adjust the plastic feet on the floor cabinets for easy levelling.

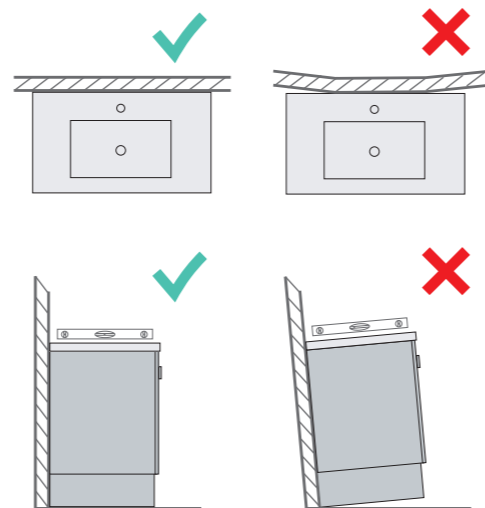

✓ HARDWARE INCLUDED

● = Floor/Tall Cabinet

● = Wall Cabinet

● = End Panel / Washer Stack

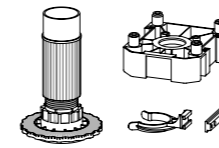

Plastic Legs



10mm Plugs

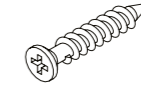

28mm Hospa Screws

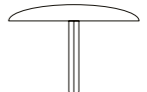

Cover Caps

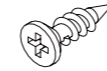

5/8"x6 Screws

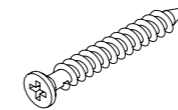

40mm Hospa Screws

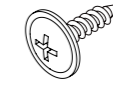

Gold Screws

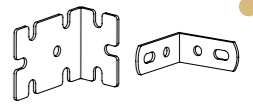

L-Brackets

✓ TOOLS YOUR TRADESPERSON WILL NEED

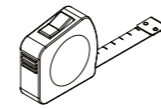

Tape measure



Pencil

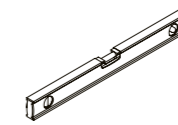

Spirit level



Safety Gear

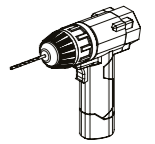

Cordless drill and/or impact driver
With 3 & 5mm drill bit

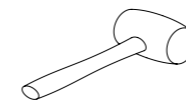

Rubber Mallet

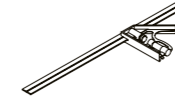

Combination Square



Cabinet Stand
(Recommended for wall cabinets)



Electric Planer
(For trimming filler panels)



Jig Saw



IMPORTANT TIPS



- Your kickboard height is 125mm, keep this in mind when levelling your Tall and Floor cabinets.
- Keep checking levels throughout the installation.
- Use the supplied 28mm screws to join all adjoining floor and tall cabinets together and all adjoining wall cabinets together before fixing the cabinets to the wall. This will help with easier cabinet installation and overall levelling.
- Remove all doors / drawers whilst installing, it will be much easier and you will avoid damaging panels. **No damages will be recognised after installation has begun.**
- Avoid sliding / dragging cabinets, lift or use a trolley wherever possible.
- A licensed Plumber is to install sink and tapware.

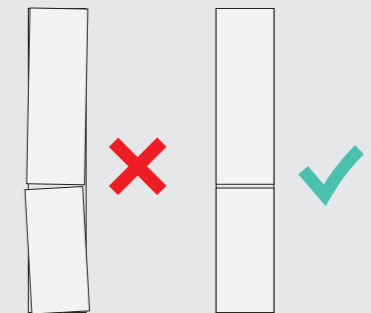

IT IS THE RESPONSIBILITY OF THE INSTALLER TO MAKE ANY ADJUSTMENTS TO DOORS/DRAWERS AFTER INSTALLATION IF REQUIRED.

Door and Drawer adjustment instructions from page 10.

STEP BY STEP INSTALLATION GUIDE

STEP 1

Complete your 'Prior to Installation' checklist and identify which end to start your installation from. See below.

STEP 2

Install your floor and tall cabinets. Level all cabinets by adjusting the plastic feet and then fasten to the wall using appropriate screws, and fastening to studs. This includes installing washing machine & dryer support rail, end panels/fillers where applicable. See page 5 for instructions.

STEP 3

Install benchtop (see page 7 for instructions).

STEP 4

Install wall cabinets and end panels/fillers where applicable (see page 7 for instructions).

STEP 5

Install kickboards (see page 8 for instructions).

EXTRAS & ADJUSTMENTS

Install any extras (eg. hanging rail) see page 9 for instructions.

ENJOY YOUR NEW LAUNDRY!

STEP 1: WHERE TO START YOUR LAUNDRY INSTALLATION

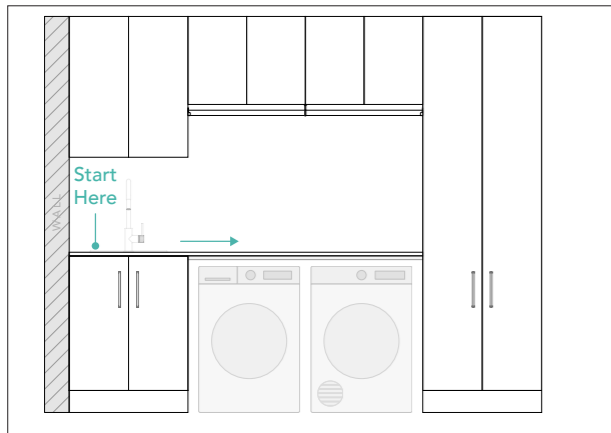

If your laundry is placed in a corner/against wall, start your installation here.

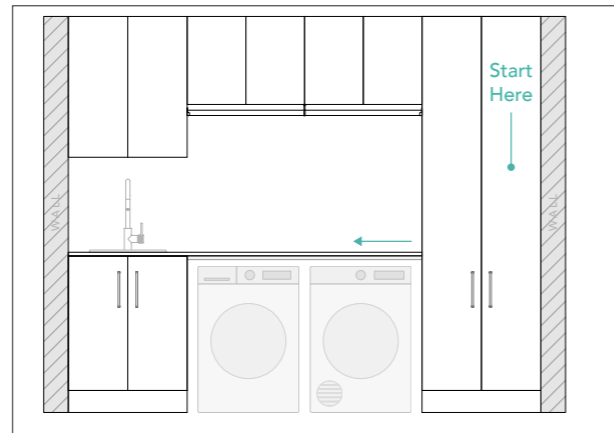

If your laundry is between walls, start the installation from the tall cabinet. If there is no tall cabinet, start from either side. Tip - measure the total space first to ensure your fillers are even on either side.

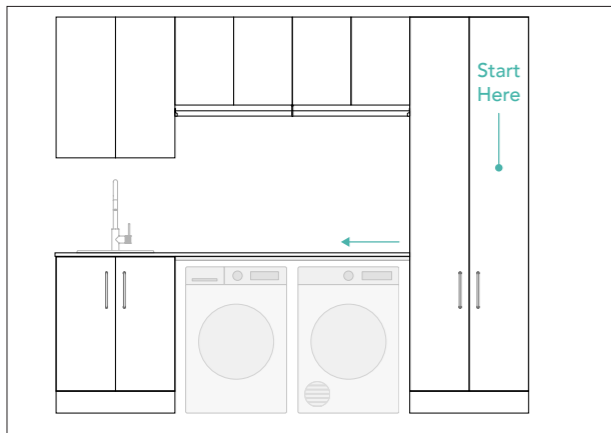

If your laundry is not placed up against a wall start the installation from the tall cabinet. If there is no tall cabinet, start from either side.



Scan for video on correct method to install plastic legs.

STEP 2: TALL & FLOOR CABINETS

1. ATTACH PLASTIC ADJUSTABLE FEET

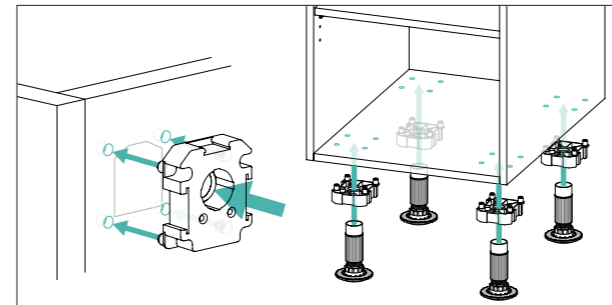

Attach the plastic adjustable feet (supplied) to your cabinet. Use a **rubber mallet** to carefully knock in the plastic plinth, aligning it with the engravings on base of cabinet (2/3 at the front and 2/3 at the back) then use the supplied 40mm screws to fasten using the 2 holes. Finally, push fit the plastic legs into the centre slot of the plinth. (Do not use a regular hammer as this will break the plastic plinth).

NOTE: MEASURE & POSITION



Measure and place cabinets in position. If cabinet end is against a wall - Place cabinet 16mm away from your starting wall (to allow for the filler strip if one has been ordered). **Note - If going in between walls, your filler gaps should be evenly spaced. If this filler gap is larger than 16mm, use a wide filler. See page 6 for further details on filler installation.**

NOTE: SPLIT TALL CABINETS

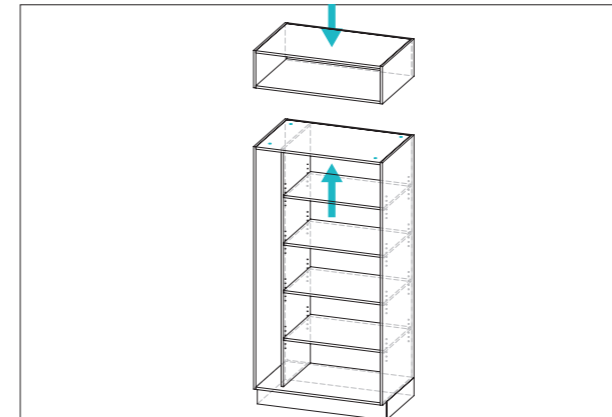

Tall cabinets over 600mm wide will be split into 2 parts and will require joining before installation.

Align top and bottom sections of tall cabinet and use the provided 28mm Hopsa screws to affix cabinets together. Screwing upward through the lower cabinet through the holes provided and into the above cabinet.

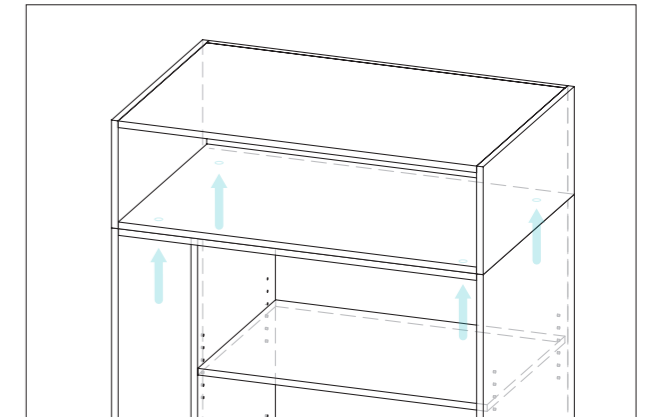

2. LEVEL & ADJUST



Check cabinets are level in all directions and adjust if needed.

Turn end of plastic legs to lift or lower legs until cabinet(s) are level in all directions. Use through holes in back of base to adjust back legs using a phillips head screw driver. **Keep in mind the kickboard is 125mm high so don't go too low or high.** When finished adjusting, use 10mm plugs to cover the through holes at the back of the base.

STEP 2 (CONT): TALL & FLOOR CABINETS

3. LOCATE PLUMBING & DRILL HOLES

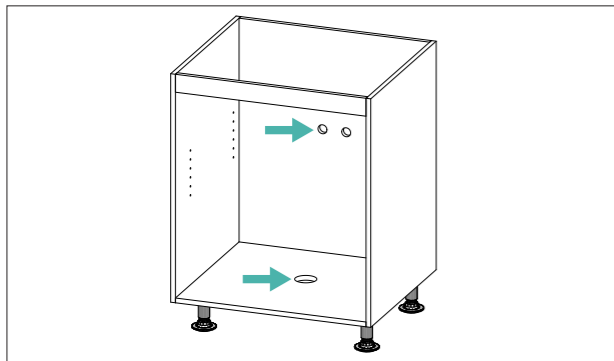

Locate plumbing and drill appropriate sized hole in base and back panel of cabinet for services.

Note: If drilling holes in drawer cabinets be sure to cover drawer runners and vacuum after to prevent debris from entering runner.

4. FASTEN CABINETS TO WALL



Once all cabinets are level, fasten together and to wall.

- 1 - Fasten cabinets together using provided 28mm Hopsa screws.
- 2 - With 5mm drill bit, pre-drill through back of cabinet into wall studs.
- 3 - Fasten cabinet to back of wall with appropriate screws/bolts. It is recommended to fasten at the top and bottom of the cabinet.

Note: Where a stud or support beam cannot be located, use an appropriately sized hollow wall anchor. Cabinet must attach to a minimum of 1 stud with 2 fixings.

7. ASSEMBLE WASHING MACHINE SUPPORT RAIL

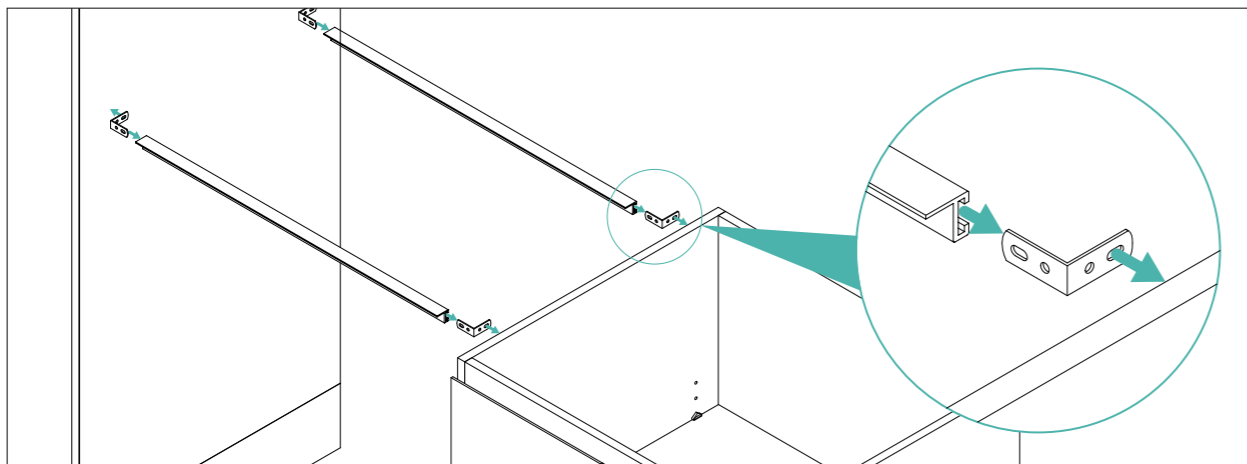

The Washing Machine and Dryer benchtop support rail will come in either single (675mm) or double (1350mm) size with brackets and screws used to assemble the unit.

- 1 - Check floor level and measure screw points out for each cabinet, setting back the front rail from the front edge by roughly 100mm and running the rear rail next to the wall.
- 2 - Screw the supplied L-brackets into one cabinet with flange at the front (see diagram) and slide support rail on with slot facing the wall.
- 3 - Slide L-Bracket into the other end of the rail and check level before fastening into other cabinet.

TIPS: END PANEL & FILLER PANELS

NOTE: FILLER / END PANELS

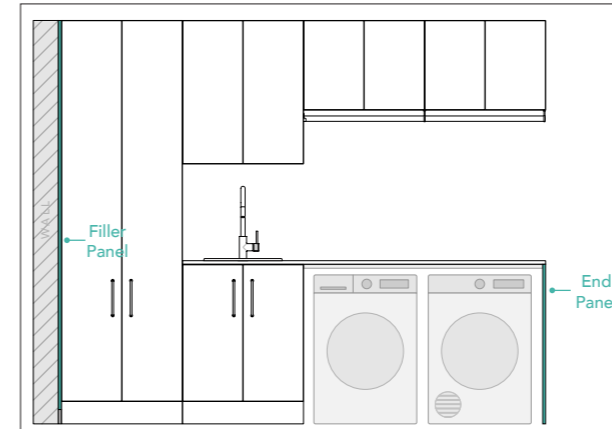

Install filler and/or end panel(s) throughout installation where applicable.

Filler Panels:

1. Place filler strip between the cabinet and wall.
2. You may need to plane the filler panel to fit/fill depending how big the gap is or if your walls are not plumb.
3. Using 28mm Hopsa screws (supplied), secure filler panel through the inside of the cabinet, ensuring you use a 5mm bit to pre-drill holes to prevent damage.

End Panels:

1. Once cabinets are in place and level, measure out distance for washing machine cavity as indicated by the support rail and attach end panel to wall using supplied L-Brackets.
2. Attach washing machine support rail to end panel.
3. Using small L-brackets, secure end panel to floor at the front and to the wall at the back, then apply non-acidic silicone along bottom edge of end panel to secure further.

Note

- Be mindful to allow extra depth for push to open doors.

STEP 3: BENCHTOP

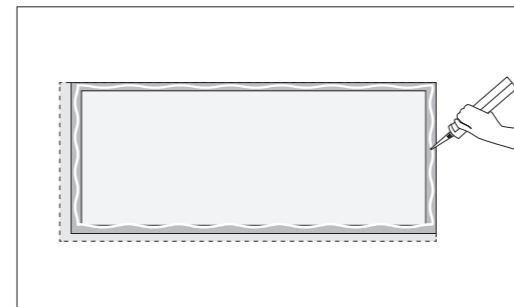

Apply non-acidic silicone to top edges of floor cabinets and any support rails. With the help of someone else, lift benchtop in place. Ensure the top has overhang (where needed) and is level. Seal all edges with a non-acidic silicone.

Note: Allow to set for 24hrs before continuing.

LICENSED PLUMBER IS TO INSTALL SINK & TAP

NOTE FOR ALL UNDERMOUNT SINKS YOU MUST USE SINK CLIPS & SILICONE

STEP 4: WALL CABINET

Note: If you have ordered open shelves, attach these to your wall cabinets prior to mounting.

1. POSITION AND LEVEL

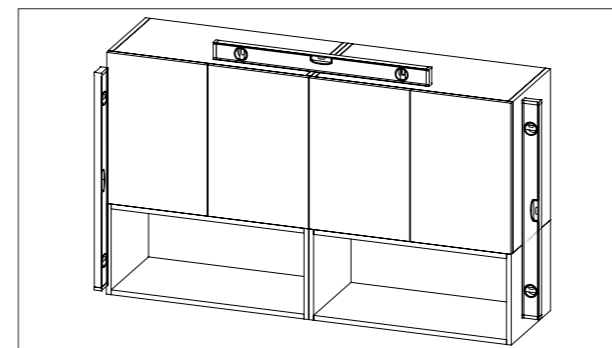

- 1 - With the help of someone else, lift wall cabinets and place in position. You may want to use cabinet stands to help.
 - 2 - Check levels and ensure cabinets align with one another.
- Note - If going in between walls, your filler gaps should be evenly spaced. If this filler gap is larger than 16mm, use wide filler.**

2. FASTEN CABINETS TO THE WALL

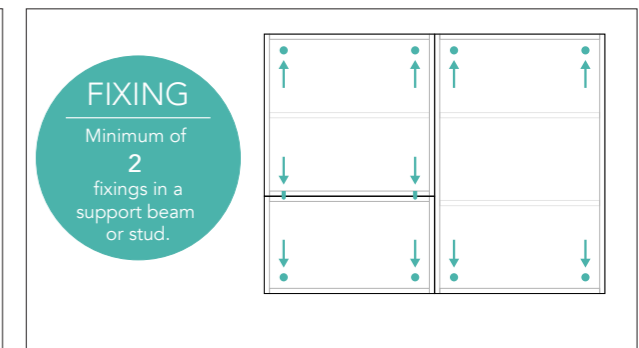

- 1 - Mark stud positions.
 - 2 - With 5mm drill bit, pre-drill through back of cabinet into stud.
 - 3 - Fasten cabinet to back of wall with appropriate screws/bolts. It is recommended to fasten at the top and bottom of the cabinet.
- Note:** Where a stud or support beam cannot be located, use an appropriately sized hollow wall anchor. Cabinet must attach to a minimum of one support beam with two fixings.

STEP 6: KICKBOARD

1. FASTEN PLASTIC CLIPS

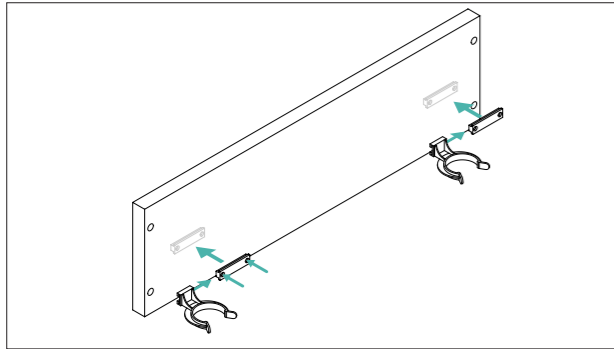

1. Screw on plastic slides to kickboard face using supplied 5/8"x6 screws (and back of side toes if panel is exposed), with the larger side outward as shown.
2. Slide on plastic clips.

2. SECURE KICKBOARD (NON-EXPOSED SIDE)

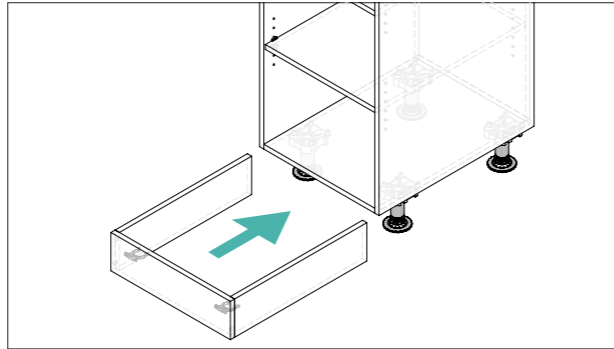

For floor cabinets between other cabinets, push fit side toes into face of kick and slide under cabinet until plastic clips lock into place.

3. SECURE KICKBOARD (EXPOSED SIDE)

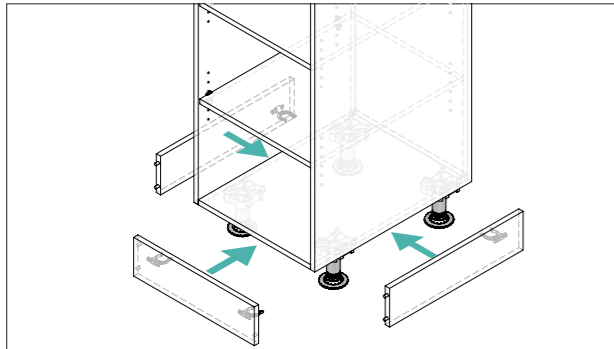

For cabinets with an exposed side, clip each side toe in then slide front toe in until plastic clips engage, ensuring the dowels align correctly.

4. SEAL KICKBOARD

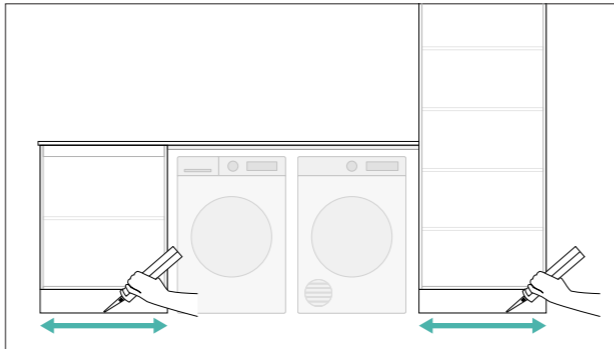

1. Ensure kickboard is firmly in place.
 2. Seal kickboard at bottom and top edge with silicon, to prevent water penetration from occurring.
- Allow to set for 24hrs.**

Note - you may need to plane some material off the kickboard to fit if your floor is uneven.

Note: You can use tall fillers or end panels as kick boards if you would prefer a continuous kickboard.

FINISHING TOUCHES

Use the cover caps provided to cover the screw holes.

TIPS: WASHER STACK END PANELS

NOTE: WASHING MACHINE STACK END PANEL

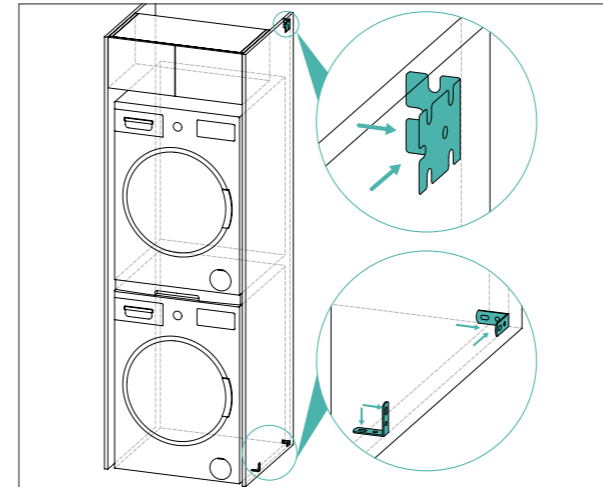

1. Use provided L-brackets and gold screws to fasten end panel to the wall.
2. Attach large L-bracket to top of panel and wall, behind where the cabinet will sit.
3. Attach 2 small L-brackets to end, fastening the front one to the floor and the rear one to the wall or skirting board.
4. Apply non-acidic silicone along bottom edge of panel to seal and secure end panel further.

HANGING RAIL INSTALLATION

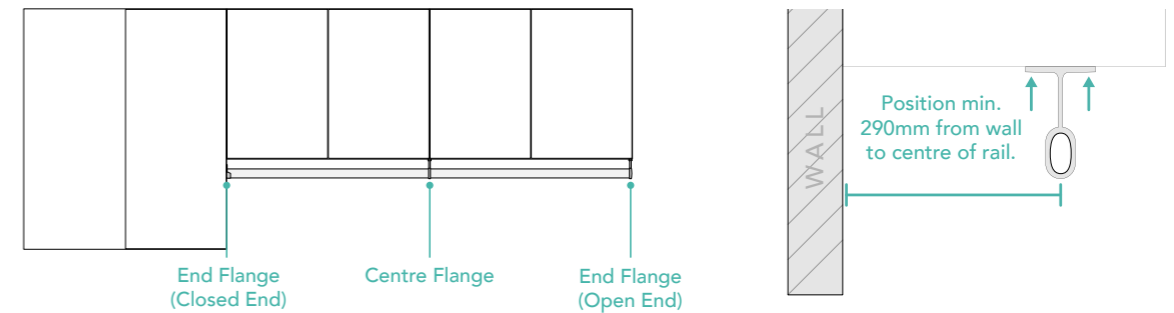

Installing Hanging Rail

- 1 - Place centre and end flange on rail. (You may not need a centre flange if you have a short rail length, less than 1m).
- 2 - Mark and pre-drill position of rail flanges on underside or side of cabinets depending on configuration.

Note, we recommend positioning the rail a minimum of 290mm from the back wall/splashback to the centre of the rail so you have enough room for coat hangers.

- 3 - Using screws (supplied) fasten rail flange to underside of cabinets.

PUSH TO OPEN DOOR ADJUSTMENT

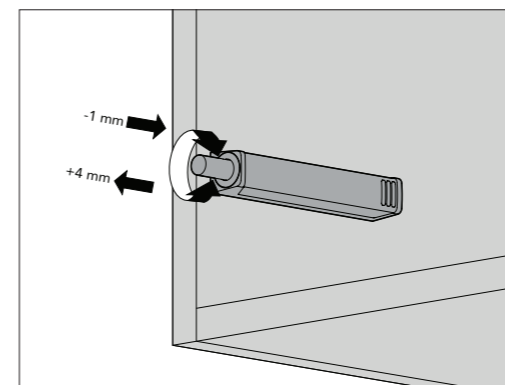

To align your push to open door, turn the knob to move the door in 1mm or out up to 4mm until door is flush.

DOOR HINGE ALIGNMENT

SIDE ADJUSTMENT

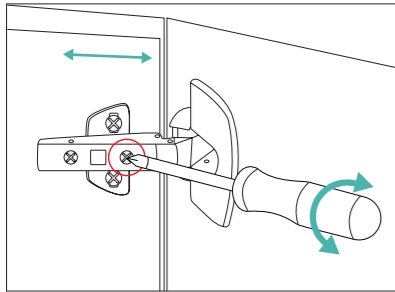

Use front screw to move door to the left or right, or to level each door.

DEPTH ADJUSTMENT

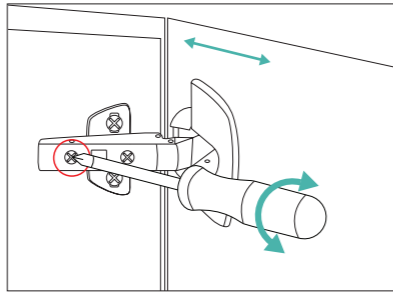

Use back screw to move door inward or outward from carcass.

HEIGHT ADJUSTMENT

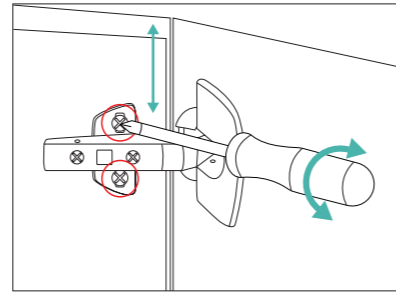

Loosen the top and bottom screw on mount plate, adjust door height by moving door up or down, then retighten screws.

DOOR HINGE INSTALLATION

REMOVING & INSTALLING DOORS

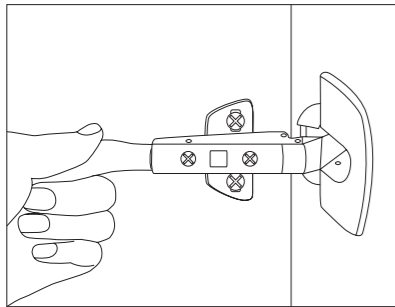

TO REMOVE DOORS:

Apply finger pressure to clip at back of hinge and pull forward to release.

TO INSTALL DOORS:

Align door hinge with hinge mount on carcass, press back of hinge into place and listen for a 'click' to lock the hinge in place. You may need to apply a little force to lock the hinge in place.

REMOVING HINGE FROM DOOR

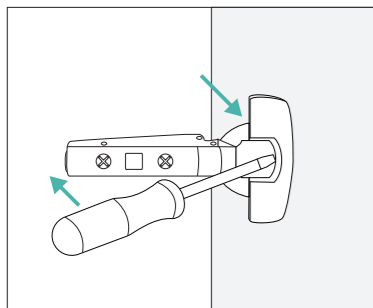

Once you have removed door from the cabinet, using a flat head screw driver, lift and release the top cover plate.

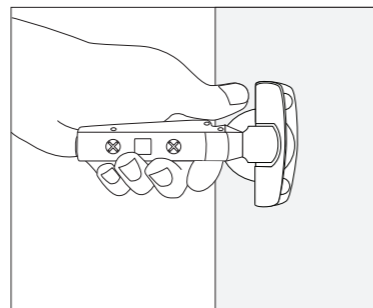

Pull hinge up and out from door. You may need to wiggle the hinge to loosen and use a little force.

REPLACING HINGE ON DOOR

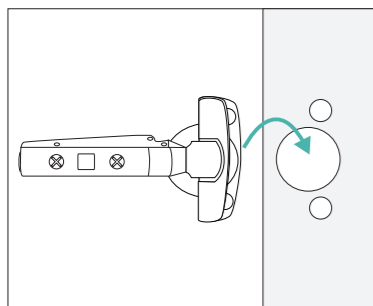

With top cover plate lifted, place hinge into position on door and insert into holes until flush.

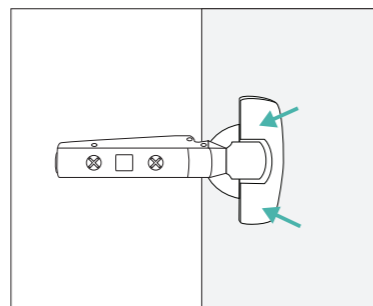

Once secured in position, click cover plate down to lock into place.

PRESSED METAL DRAWERS

DRAWER HEIGHT ADJUSTMENT

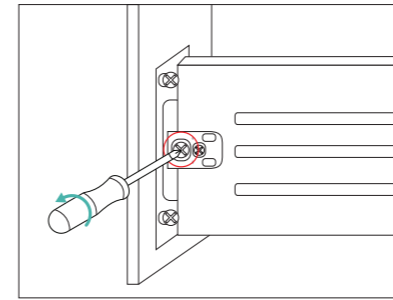

Loosen the front screw.

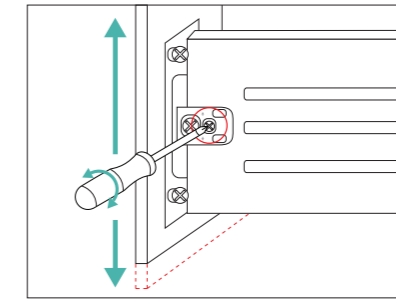

Turn the back screw to adjust the height of the drawer front. Turn anti-clockwise to go up and clockwise to go down.

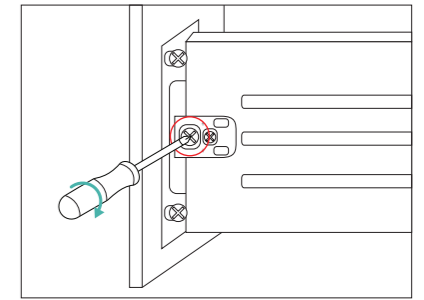

When drawer height is aligned, tighten the front screw. Repeat on both sides of drawer if needed.

DRAWER LATERAL ADJUSTMENT

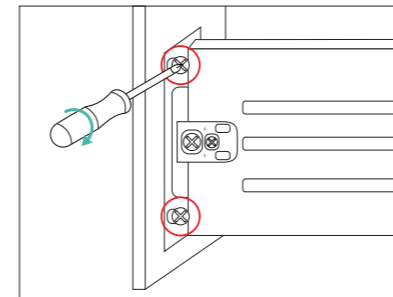

Loosen top and bottom screws on both sides of drawer.

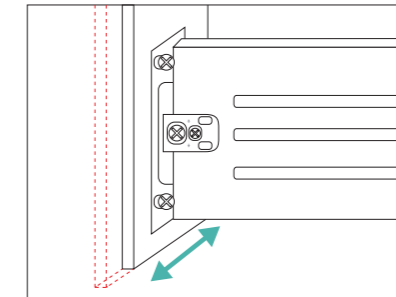

Slide drawer front left or right.

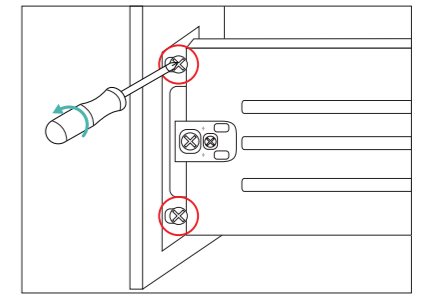

When drawer front is aligned, tighten all screws in place.

REMOVING & INSERTING DRAWER

REMOVING

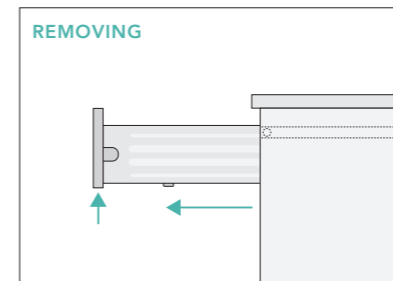

Slide drawer out, lift up and out to remove.

INSERTING

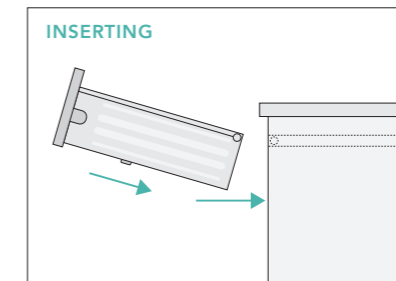

Insert drawer on an angle. Align top of metal sides onto runners in cabinet and push into place.

DRAWER FRONT REMOVAL AND INSTALLATION

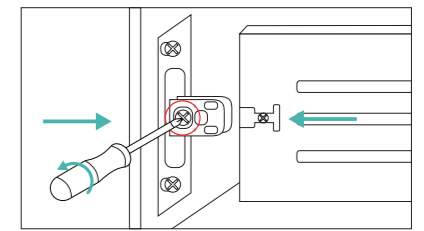

To remove drawer front: Loosen front screw on both sides until drawer front comes off.

To install drawer front: Align drawer front with sides of drawer and tighten front screw to secure in place.

TROUBLESHOOTING - HOW TO RE-ENGAGE THE SOFT-CLOSE ADAPTER

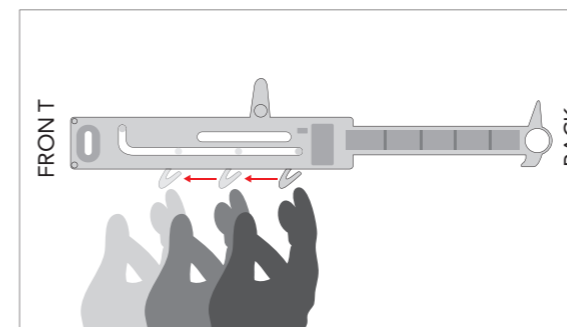

Soft-close not working?

1. Remove drawer.
2. On inside of cabinet, re-set the trigger by pulling the tab towards the front of the cabinet.
3. Insert drawer and the soft-close should re-engage.

Note: If this does not solve the problem, your cabinet may not be level or plumb as there could be an alignment issue.

DELUXE SOLID SIDED DRAWERS

REMOVING DRAWER

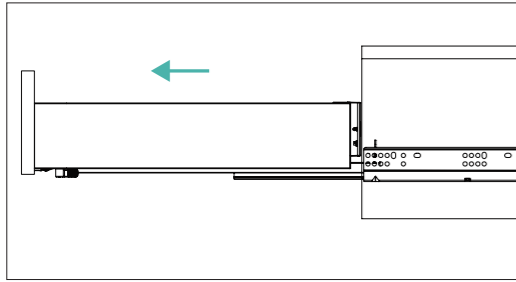

Pull drawer out.

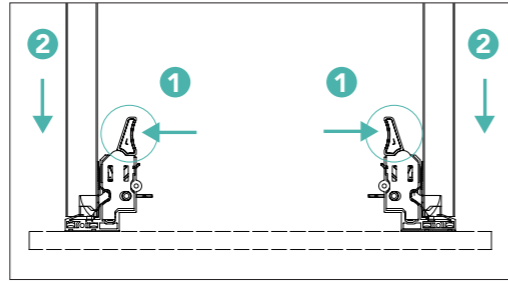

Squeeze both levers in on the underside of the drawer, at the same time (to activate release) and pull drawer out to remove.

INSERTING DRAWER

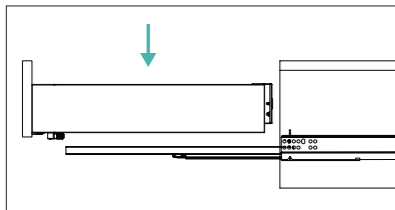

Extend drawer runners out and place drawer on runners.

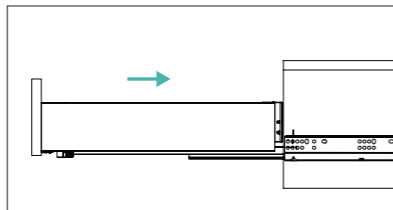

Push drawer closed until it is about 2cm out from the vanity.

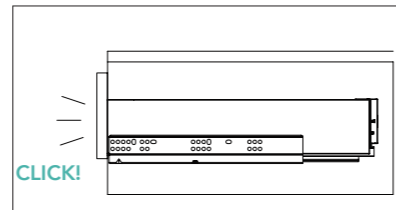

You will then need to apply a little force on the drawer front (near the bottom) to push closed and connect runners in place.

DRAWER FRONT REMOVAL AND INSTALLATION

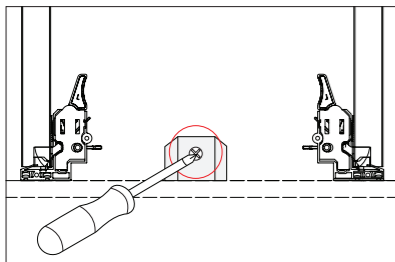

Depending on width of drawer you may need to unscrew and remove middle bracket on the under side of the drawer.

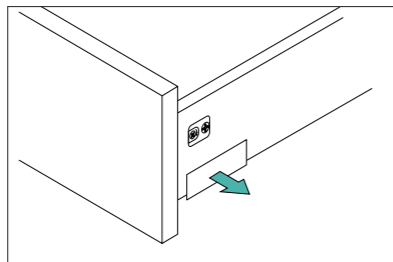

Remove cover cap to access drawer adjustments panel.

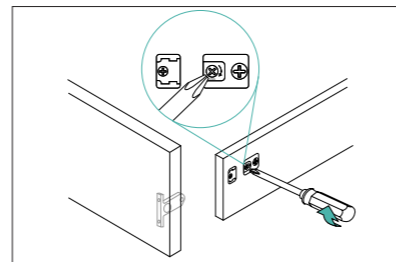

Turn release screw clockwise on either side of the drawer to release drawer front.
To re-attach drawer front line up the brackets on the drawer front with drawer sides and push into place until you hear a click.

LATERAL ADJUSTMENT

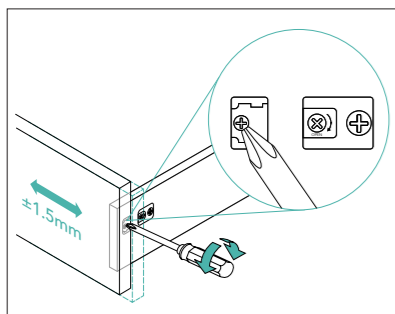

DEPTH ADJUSTMENT

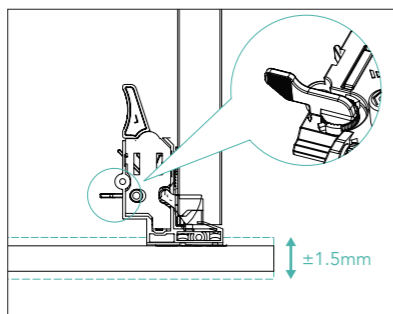

HEIGHT ADJUSTMENT

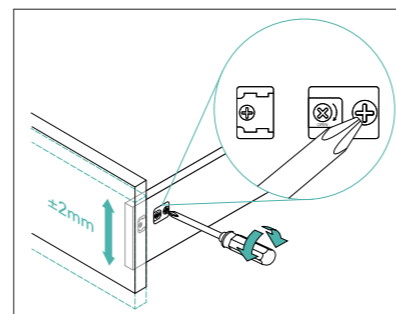

HAMPER INSTALLATION & ADJUSTMENTS

PARTS INCLUDED

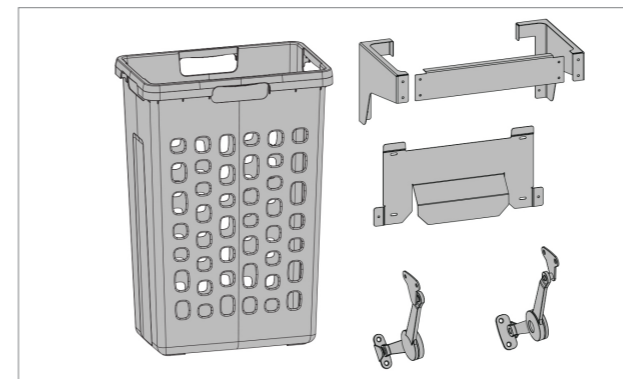

OVERALL DIMENSIONS

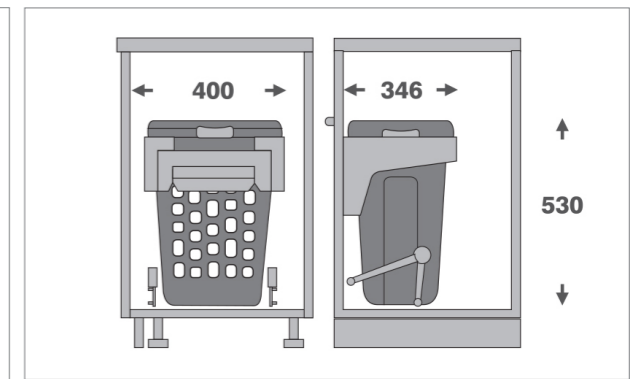

BRACKET

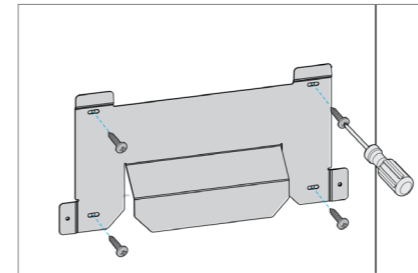

Screw bin tray bracket to the door.

ARMS

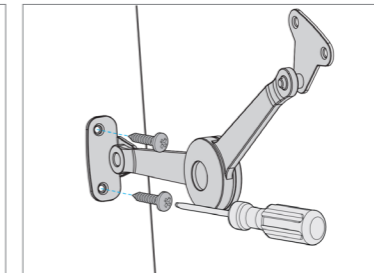

Screw both soft close arms to door.

HINGES

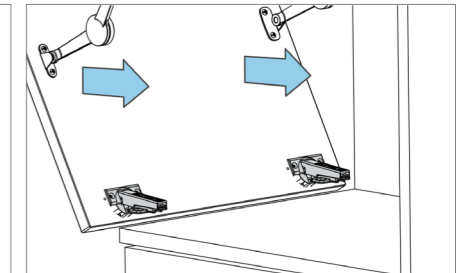

Mount the hinges to the door as per the instructions on previous page (page 20).

ADJUSTMENTS

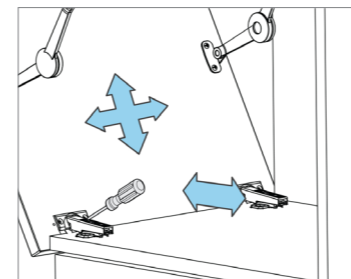

Make door adjustments using the lower hinges.

ATTACH ARMS

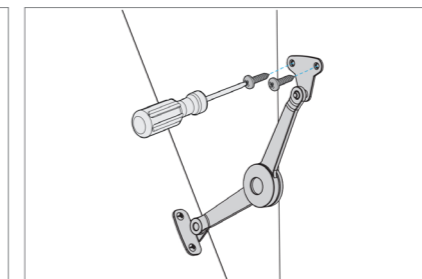

Screw both soft close arms to cabinet.

ASSEMBLY

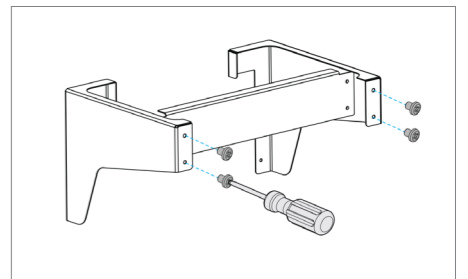

Assemble bin tray parts.

BRACKET

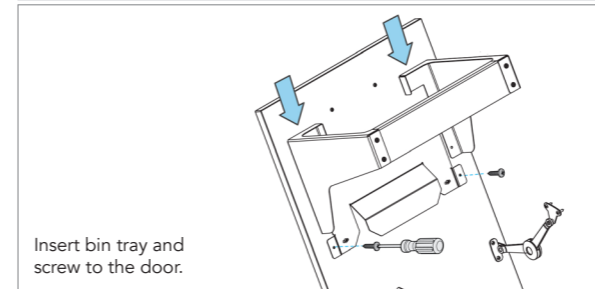

Insert bin tray and screw to the door.

BRACKET

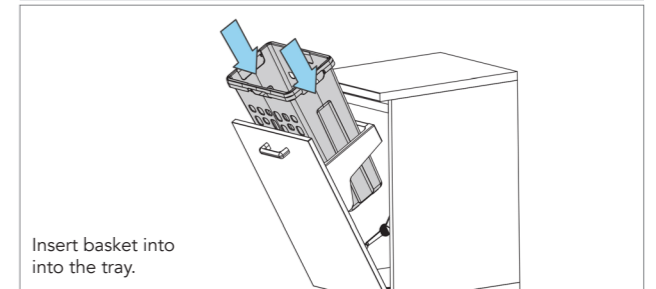

Insert basket into the tray.

Note: Hamper door adjustments, made using bottom hinges. See left page (pg. 20) for adjustment instructions.



CARE & MAINTENANCE

TIPS

- ADP products are produced from materials that are well suited to the laundry, however it is important that your laundry has sufficient ventilation to avoid excessive moisture due to water sources.
- High humidity will lead to permanent dampness and mould, resulting in deterioration of the materials.
- Care must always be taken to dry any excessive moisture or water spillage.

CABINETS

- To maintain the finish on your cabinet use only a soft cloth and weak solution of non abrasive detergent.
- To remove scratches, marks, etc. on two pack polyurethane, rub gently with car cutting compound, car polish or household brass/silver cleaner.
- Goods used in construction are water/moisture-resistant, but **not water-proof**.

GRANITE COMPOSITE SINKS

- Rinse sink with water after use and wipe dry with soft cloth.
- For stubborn stains, we recommend to use granite cleaner or a mild non-scratch formula cleaner with scouring pad, then rinse well.
- NEVER USE steel wool to clean the sink, this will scratch the surface.
- DO NOT use the sink as a cutting board or place hot items directly on the sink surface. Do not pour boiling oil into the sink because it may cause deformation of the drainage pipe and always run cold water when pouring boiling liquids into sink.
- AVOID strong bleaches, household chemicals, soaps and aggressive chemical solutions contacting with the sink. If it occurs, rinse thoroughly and wipe it dry quickly.

STAINLESS STEEL SINKS

- Rinse sink with water after use and wipe dry with soft cloth.
- For stubborn stains, we recommend a mild non-scratch cleaner such as a vinegar-based cleaner with a non-abrasive sponge, then rinse well. Clean often to avoid to avoid limescale building up.
- DO NOT use steel wool to clean the sink, this will scratch the surface.
- AVOID strong bleaches, silver dip cleaners and aggressive chemicals such as denture cleanser and photo developing liquids. If it occurs, rinse thoroughly and wipe it dry quickly.
- AVOID leaving citrus fruit juice, salt, vinegar, mustard, pickles and mayonnaise on your surface for prolonged periods. These foods can cause pitting and corrosion.

CHERRY PIE PREMIUM SOLID SURFACE BENCHTOPS

- Wipe clean with a soft damp cloth or sponge.
- For basic stains clean with mild detergents. You can use a non abrasive polish or Brasso for tougher stains.
- Cherry Pie benchtops have excellent heat and chemical resistant properties compared to other surfacing products, however to preserve the surface and protect against damage from heat, do not place hot items directly on the surface. Even though Cherry Pie can withstand high temperatures, prolonged periods or extreme heat can cause permanent damage.



TROUBLESHOOTING

PROBLEM	LIKELY CAUSE	SOLUTION
I have noticed damage to my product, should I install it?		No - advise the store you purchased the product from before installation.
Where can I find specifications or more information for the product I have purchased?		Go to www.adpaustralia.com.au/laundry . If you still can't find what you're looking for, call us on (02) 4271 2444.
My cabinet doors are out of alignment.	There may have been some movement in transportation and installation which causes doors to become unaligned.	Follow the hinge adjustment instructions on page 10 to align doors.
My cabinet drawers are out of alignment.	There may have been some movement in transportation and installation which causes drawers to become unaligned.	Identify drawer type and follow the corresponding instructions to adjust and align drawer (from page 11).
My drawer is not closing properly.	Incorrect installation or an obstruction preventing the drawer from closing.	- Check that there is nothing obstructing the drawer (eg. plumbing or tap hose). - Check the drawer box has been installed correctly (page 11). - Check the cabinet has been installed correctly (eg. is it level & plumb?).
My metal-sided drawer with soft-close adapter is not working properly?	The soft-close adapter may not be engaged.	Remove drawer. On inside of cabinet, re-set the trigger by pulling the tab towards the front of the cabinet. Insert drawer and the soft-close should re-engage.
I am missing something from my order (eg. sink or kickboard).		Notify place of purchase of missing parts.
I have a stain or mark on my benchtop.		For basic stains clean with mild detergents and a soft cloth. For tougher stains, clean with a non-abrasive polish or Brasso with soft cloth.
I am not sure what to clean my cabinet or product with.		Use a soft cloth and weak solution of non-abrasive detergent to gently wipe over the cabinet. See page 14 for more.



WARRANTY

NOTE: Unless otherwise stated warranties for ADP products are as follows:

PRODUCT	DOMESTIC WARRANTY	COMMERCIAL WARRANTY
Cabinets	10 years	1 year
Cherry Pie Premium Solid Surface benchtops	10 years	1 year
Stainless Steel Sinks	15 years	1 year
Granite Composite sinks	10 years	1 year
Hardware	7 years	1 year
Electrical / Lighting / Plumbing Fittings	1 year	1 year



WARRANTY

Our products come with guarantees that cannot be excluded under the Australian Consumer Law. You are entitled to a replacement or refund for a major failure upon inspection by an authorised representative where a product is found to be defective in construction, material or assembly. You are also entitled to have the goods repaired or replaced if the goods fail to be of acceptable quality and the failure does not amount to a major failure, free of charge.

CONDITIONS

1. Items must be installed by a licensed tradesperson.
2. Failure is due to a fault in the manufacture of the product.
3. Proof of purchase is provided.
4. The installation of the product is in accordance with the instructions provided.

EXCLUSIONS

To the fullest extent permitted by law, the manufacturer excludes all liability for damage or injury to any person, damage to any property and any indirect consequential or other loss or damage. Manufacturer will not be liable for the cost of installation or removal of any unit and the warranty will be VOIDED if damage occurred during or after INSTALLATION or a damaged or incorrect unit has been installed. Door and drawer adjustment; Unsuitable or improper use; Incorrect installation or installation not in accordance with the instructions provided; Installation or part installation by the purchaser or any person other than a LICENSED tradesperson; Normal wear and tear; Inadequate or complete lack of maintenance; chemical, electrochemical or electrical influences; excessive heat damage or Harsh detergents or abrasive cleaners used on product finishes, are NOT considered a warranty issue.

CLAIM PROCEDURE

For all warranty queries customers are to contact the branch where the product was purchased. These details can be found on your purchase invoice.

SERVICE CALL OUT FEES & CHARGES

In the event of a call out for issues covered under the ADP manufacturer warranty, no call out fees will apply.

If ADP is called out and the cause of the issue falls within the warranty exclusions or the installation instructions have not been adhered to, the following charges will apply:

Call out fee: \$198.00 initial cost, first 15 minutes included.

Service time onsite: \$24.75 / billed in 15 minute increments.

Call out times: Business hours 9am - 5pm.

Note: Response time will depend on technician availability.



WARRANTY AGREEMENT - HOME OWNER TO KEEP

IMPORTANT: Warranty form to be completed by a licensed qualified tradesperson responsible for the installation of this unit. Any warranty will be VOIDED if unit is not installed by a licensed qualified tradesperson.

Cabinets Installed by: _____ Phone: _____

Trade & license number: _____ Date: _____

Product name/description: _____ Purchase Date: _____

Product Warranty Number (found on door or drawer inside unit):



Architectural Designer Products Pty Ltd.
P.O. Box 1455, Unanderra NSW 2526 | ABN 34 073 064 721



info@adpaustralia.com.au



www.adpaustralia.com.au



(02) 4271 2444



@adpaustralia