

Please keep me

Installation Instructions Care & Maintenance Guide Warranty

- 2 Prior To Installation
- 4 Installation Instructions
- 12 Plug & waste installation
- 14 Drawer alignment & installation
- 21 Door Hinge alignment & installation
- 24 Care & Maintenance Guide
- 29 Troubleshooting
- 30 ADP Warranty

**Hey qualified tradie!
Be a legend and please
read installation instructions
inside before installation**



If the product is not installed in accordance with these instructions, your ADP warranty may be void and the homeowner may have a claim against you (the installer).



**Hey home owner!
Please read important
care, maintenance and
warranty info inside**

✓ PRIOR TO INSTALLATION CHECKLIST



This product must be installed by a qualified tradesperson and we would expect the installation to be undertaken in a tradesperson like manner and finished to a tradesperson standard. This product carries a full warranty against faulty workmanship and materials.

Please inspect thoroughly before installation to ensure that the product has not been damaged and is correct. No claims for damage or incorrect items will be recognised after installation.

IT IS THE RESPONSIBILITY OF THE INSTALLER TO MAKE ANY ADJUSTMENTS TO DOORS/DRAWERS AFTER INSTALLATION IF REQUIRED.

Please Note: If you cannot find the installation instructions for your ADP product in this booklet please go to www.adpaustralia.com.au/resources/installation-technical/ to find applicable instructions.

1 Check Products For Any Damages

Within 48 hours of receiving your goods, unpack your ADP product and check for any possible freight damages or incorrect items.

Please contact your place of purchase to report damages or missing parts.

No claims for damages will be recognised after installation.

Please note: fixing screws/bolts are not supplied for installation.

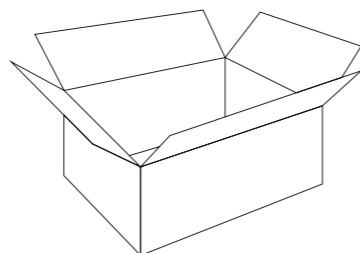

2 Positioning & Ventilation

Planning your bathroom furniture placement is critical.

Furniture must be at least 300mm away from any wet areas. Materials used in the construction of our furniture units are moisture resistant, not water proof.

Do not expose furniture to shower spray.

It is important that your bathroom is adequately ventilated to eliminate moisture build up.

High humidity will lead to permanent dampness and mould resulting in a deterioration of the materials in your bathroom.

Water damage is not covered under ADP Warranty.

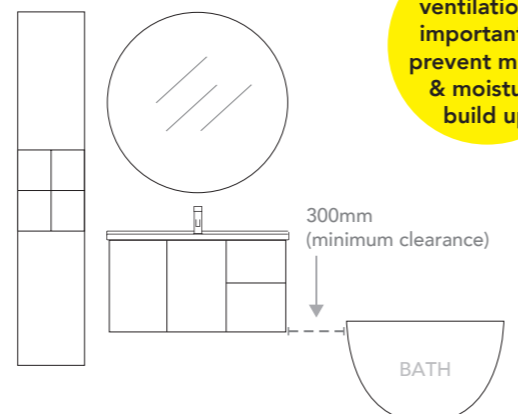

3 Check for Support Beams

Wall hung furniture & basins require fixing to a support beam fitted between the studs to give a solid wall backing to attach the vanity to.

If necessary, fix additional support noggins at desired height for cabinet and basin fixing prior to sheeting the wall.

Ensure total width of support noggin exceeds vanity width.

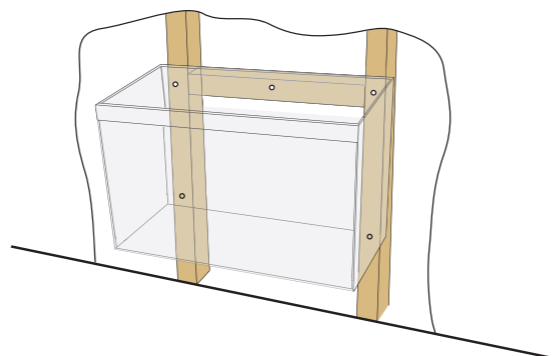

4 Check for Plumb Walls & Level Floors

Ensure the wall is plumb and straight, ensure floor is level. If you fix the product to a non-plumb wall or floor the following could happen:

- Your door or drawers will not operate correctly.
- Door or drawers will not align.
- Basins will not sit level, which may cause water to pool or not drain properly.

If it is not possible to make the wall or floor plumb and straight you must pack the vanity out so that it does not follow the out of aligned wall.

Floor standing vanities must sit on a level floor or be packed so they sit level and true.

Please note if your vanity is fixed to a bowed wall, the fastening of the fixings will force your cabinet to twist and benchtop materials may crack due to increased stress on joins and materials.

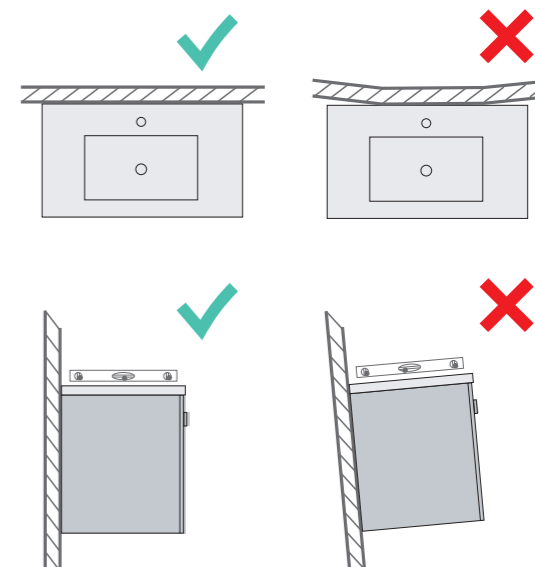

5 Check Plumbing Positions Align with Product Interior Configurations.

Take note of clearances behind drawers when considering water supply fittings inside cabinet.

Please note if your product has any electrical fittings please allow for this and talk to your electrician

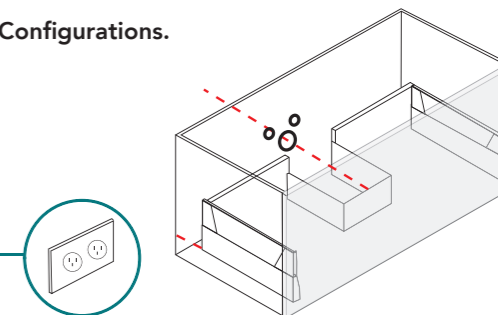

! IMPORTANT TIPS



ENSURE ALL TILES EXTEND BEHIND AND BENEATH THE BATHROOM FURNITURE.

ADP do not recommend tiling in furniture due to moisture and mould build up which can damage the material and void the warranty.

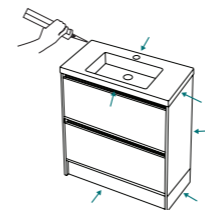

ALL AREAS WHERE CABINET/TOP MEETS WALL AND/OR FLOOR MUST BE SEALED USING A NEUTRAL CURE SILICONE.

All edges where vanity top meets cabinet, wall or surrounding furniture must be sealed with a continuous bead of silicone.

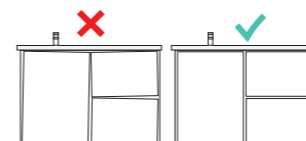

IT IS THE RESPONSIBILITY OF THE INSTALLER TO MAKE ANY ADJUSTMENTS TO DOORS/DRAWERS AFTER INSTALLATION IF REQUIRED.

There may have been some movement in transportation and installation which causes doors/drawers to become unaligned.



VANITY INSTALLATION

Which Vanity solution do you have?

STANDARD VANITY

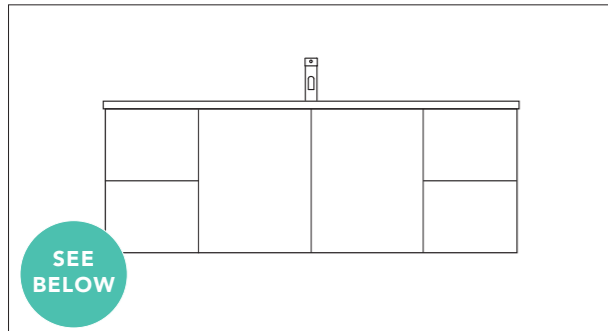

AGAINST WALL OR BETWEEN WALLS

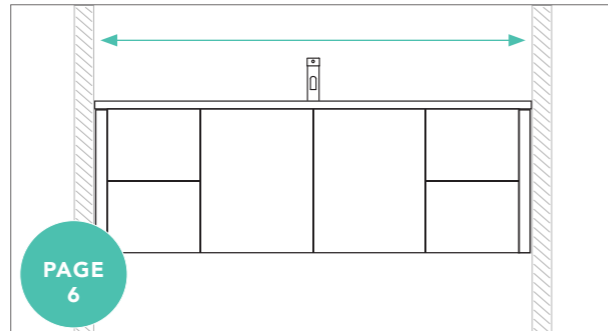

You will need to install a filler, wide filler or infill panel.

For further instructions visit www.adpaustralia.com.au
Including metal frames, stone benches and petite with rail.



STANDARD VANITY INSTALLATION

1. LOCATION

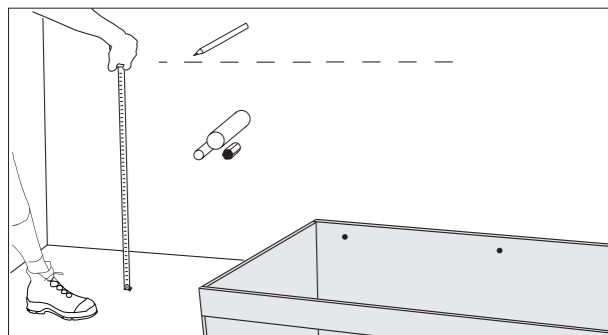

After completing the Prior to Installation Checklist on page 2, mark the position of the top of the vanity. Don't forget to factor in the top/basin thickness to get the correct height.

Note: Vanity must attach to a minimum of two support beams, mark these positions.

2. PREPARING THE CABINET

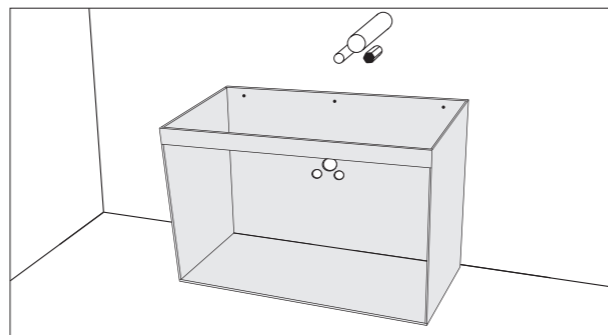

Remove doors and drawers. Measure correct plumbing locations and drill holes for plumbing in the back panel and/or base of the cabinet with an appropriate sized hole saw. Pre-drill screw locations for fastening to wall as per 'Step 4'.

3. LEVELING

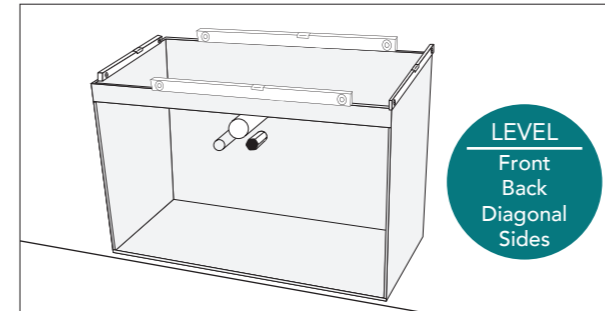

Position the vanity over the pipes in the correct position and fix with a single screw in centre of vanity to hold in place. Check the vanity is completely level.

4. SECURING THE CABINET

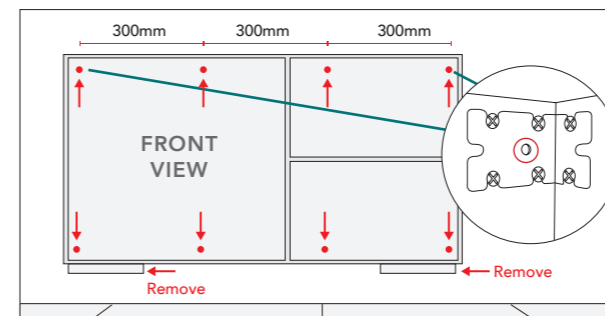

Securely fasten the vanity to the wall through back of vanity with appropriate screws/bolts at TOP and BOTTOM of cabinet. Fix the cabinet through the top left and right hand brackets and evenly space apart the horizontal fixings at a maximum of 300mm apart. For the bottom start the fixing points no further than 100mm from each end of the cabinet and no higher than 50mm from the base panel.

Note: Where a stud or support beam cannot be located, use an appropriately sized hollow wall anchor. Vanity must attach to a minimum of two support beams. Ensure fixings clear all water/electrical services in wall.

5. REMOVE TRANSPORTATION BLOCKS

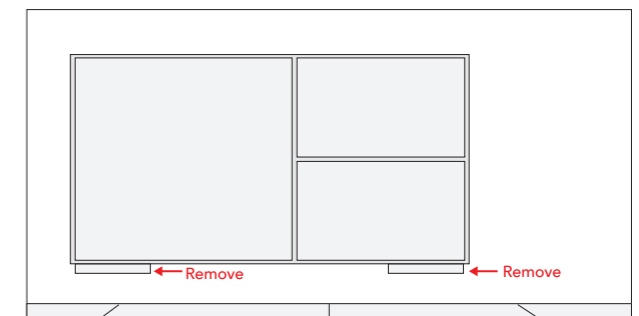

Once cabinet is secured to the wall carefully remove transportation blocks from the underside of the cabinet (we recommend using a chisel).

IMPORTANT: Before installing drawers, vacuum out drawer runners to ensure drawer runners are free of any debris as this may effect the operation.

6. FIX TOP / BASIN

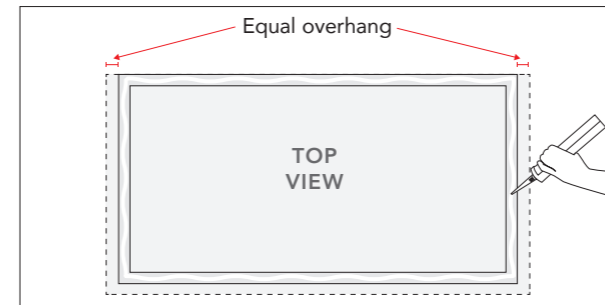

Using a non-acidic silicone, apply a continuous bead of silicone to the top four edges of the vanity and at the back where the top meets the wall. Position the top so it has equal overhang on each side, ensuring the top surface is level.

If using a separate basin, position in place and fully seal the basin to the top/cabinet using a continuous bead of silicone.

Note: Seal any visible gaps between the cabinet and the top and basin with continuous bead of silicone.

7. SEALING

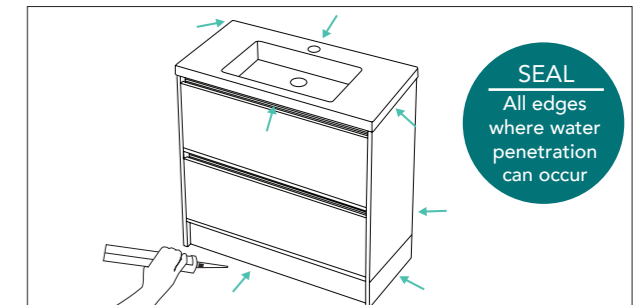

Apply non-acidic silicone to all edges where vanity top and cabinet meet the wall and floor.

Materials used in the construction of this unit are water resistant NOT water proof, so all areas need to be sealed to prevent water penetration.

Note: Gap sealant can be used in place of silicone where the unit meets tiled surfaces.



SEE PAGE 8 FOR FINISHING STEPS



AGAINST WALL OR BETWEEN WALLS VANITY INSTALLATION

1. MEASURE YOUR SPACE

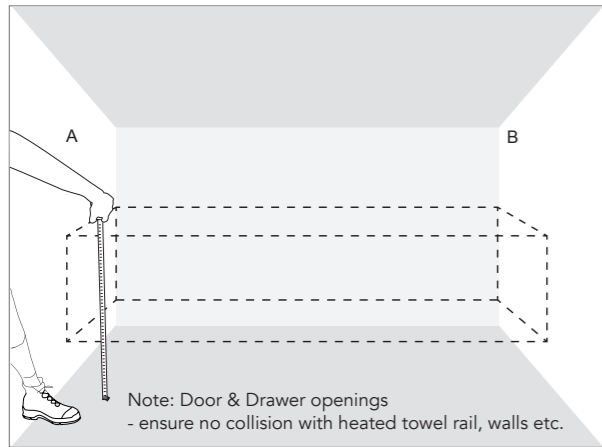

For Against Wall installation - measure out distance you need from the wall to clear any collisions or for un-plumb walls.

For Between Walls installation - measure between wall A & B check that the cabinet length, depth & height is correct for the space.

2. GO TO PAGE 4

SEE STANDARD VANITY INSTALLATION AND FOLLOW STEPS 1 TO 5

5. PLANE DOWN THE PANEL

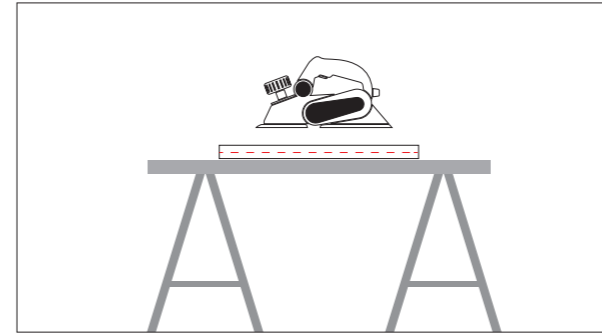

5a. Setup the filler, ensuring the part needed is face down.

5b. Using an electric planer, plane down the panel to the scribed line.

6. PRE-DRILL HOLES

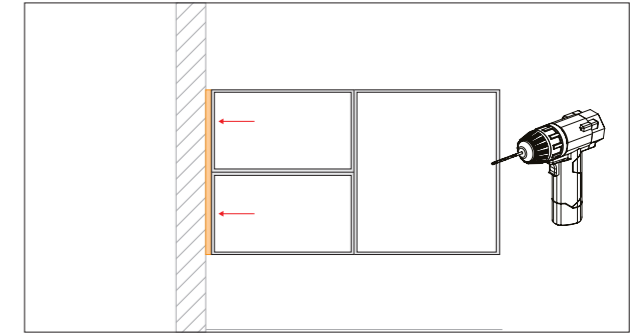

Pre-drill holes through the end panel of your carcass at the top and bottom.

Repeat on both sides if your cabinet is going between walls.

7. SECURE THE FILLER/INFILL PANELS

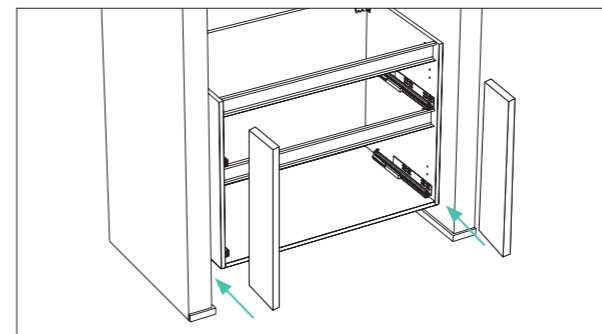

7a. Place the panels into the gaps and set them either flush with the cabinet or door front.

7b. Secure panels by screwing into place through the pre-drilled holes.



SEE PAGE 8 FOR FINISHING STEPS



Scan to watch a quick video with some handy tips on how to install a filler or infill panel

3. MEASURE YOUR FILLER/INFILL GAP

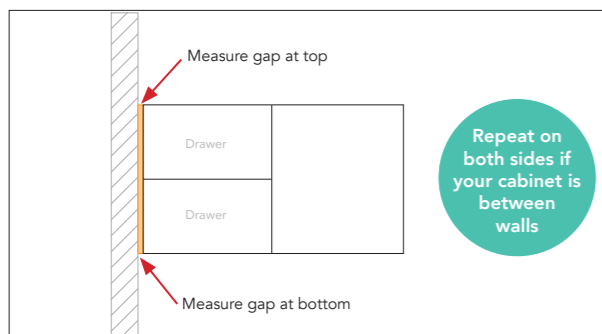

3a. Remove doors and/or drawers.

3b. Measure the gap between the cabinet and wall, measure the top and the bottom in case your wall is out of square. Repeat for both sides if your cabinet is between walls.

4. MARK YOUR FILLER/INFILL PANEL

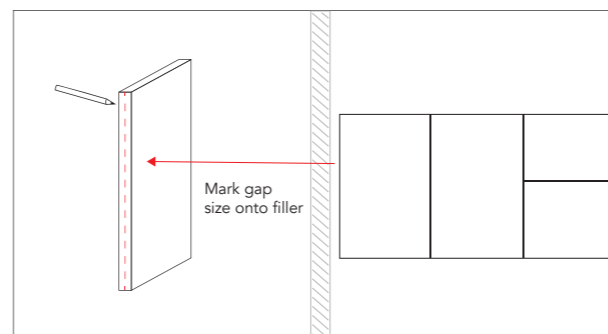

Your filler/infill panel is most likely 100mm x 16mm, so you may need to plane the filler panel down to fit/fill the gap or if your walls are not plumb. Mark these measurements on the front edge of your filler/infill panel and use a straight edge to scribe a line down the whole filler.



WIDE INFILL PANLES

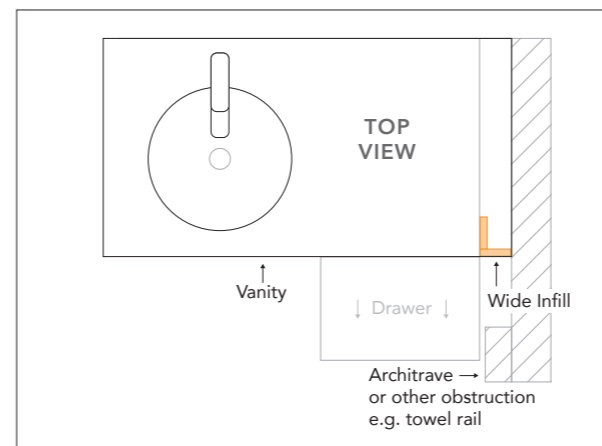

Use a wide infill panel when the drawer will not clear an architrave or obstruction. Eg. a towel rail.

⚠️ DETACHABLE KICKBOARD INSTALLATION

1. JOIN SIDE PANELS

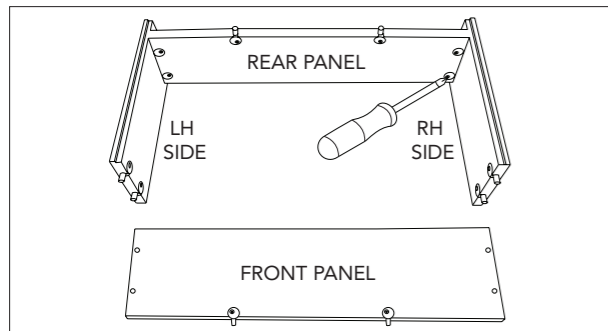

Join each side panel with rear panel. Use a phillips head screw driver to fasten the cam-locks clockwise into the pre-drilled holes.

2. JOIN FRONT PANEL

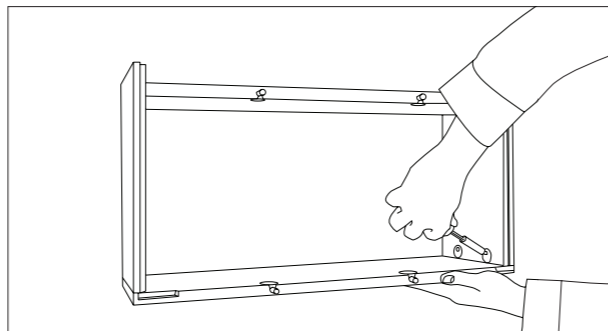

Attach and fasten the front panel to each side panel. Ensure all cam-locks are fastened.

Note: The cam-locks should be pointing directly up on the front and rear panel.

3. ATTACH CENTRE SUPPORT (FOR LARGER UNITS)

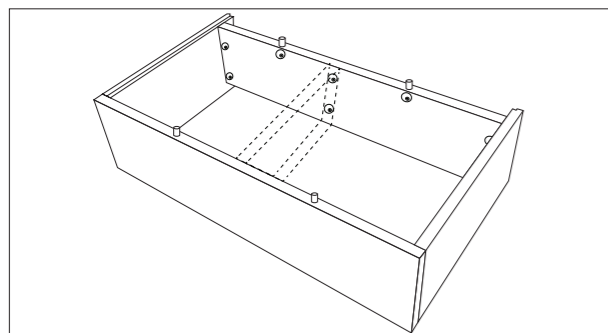

For larger units (1200mm and bigger), insert the centre support panel supplied and secure all cams.

Your kickboard is now assembled.

4. REMOVE BLOCKS & JOIN KICKBOARD TO VANITY

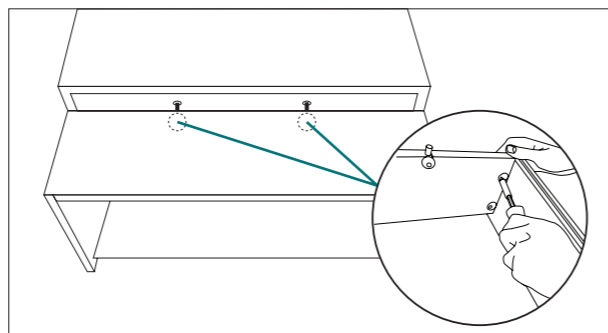

Carefully lay vanity unit on its back on a flat surface and remove transportation blocks from the underside of the cabinet (we recommend using a chisel). Using the pre-drilled holes at the base of the unit as a guide, insert the cam-locks at the top of the kickboard and fasten to vanity unit.

Note: The cam-locks should be pointing up on the front and rear panel.

🔧 FINISHING STEPS

ADJUST DOORS & DRAWERS

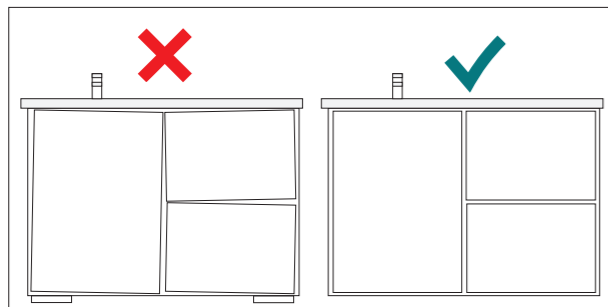

Vacuum out drawer runners to ensure drawer runners are free of any debris. Install drawers and doors back onto cabinet and make adjustments to align the doors and drawers correctly. See pages 8 -13 for instructions.

NOTE: IT IS THE RESPONSIBILITY OF THE INSTALLER TO MAKE ANY ADJUSTMENTS TO DOORS AFTER INSTALLATION.

Don't forget to remove the transportation blocks on the underside of the cabinet!

CLEANING

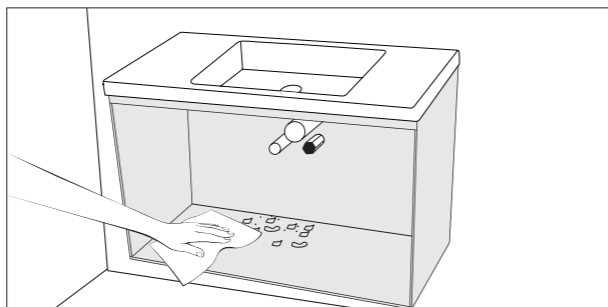

Clean all building residue from the cabinet. Dry any spillage or leakage of water on or inside the cabinet during installation.

IMPORTANT: Vacuum out drawer runners to ensure drawer runners are free of any debris as this may effect the operation.

For vanity care and maintenance see page 14.

🔧 FITTING AN OVERFLOW



Small basin set up



Large basin set up

Important Assembly Notes

- Pre-assemble kits and fit to basin prior to mounting on cabinet. This will make flange and elbow adjustment easier. (Cutting the hose to size should not be required. Never cut on serrations)

- When connecting hose to elbow and flange carefully align ends and insert fully.
- Rotate elbow and flange to eliminate low points where water can gather and avoid major kinks that stop water flow.
- Ensure hose does not obstruct basin placement on cabinet.

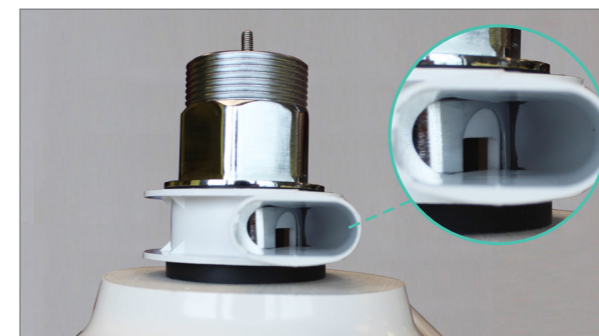

Aligning the overflow kit flange with waste overflow holes is critical to prevent leaking. The Universal Plug & Waste kit is designed for overflow alignment.

An ADP Universal Plug & Waste is required when installing overflow kits. By not using this waste you risk voiding the warranty.

See page 12 for Universal Plug & Waste instructions.

🔧 FITTING ABOVE COUNTER BASINS

Note: Basin replacement in the future is an important factor to consider when fixing and sealing basins. By limiting silicon application as per instructions allows basin removal without damage to benchtops.

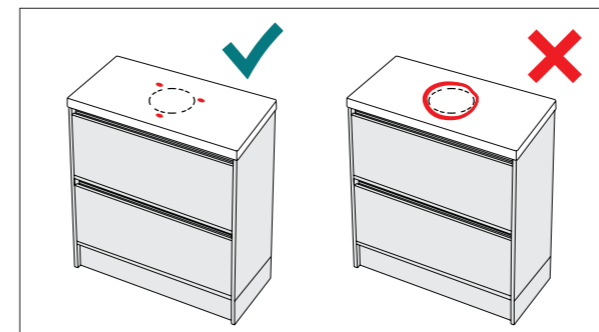

Apply 20mm silicon dots to hold basin in place, limit to 3 fixing points to enable future basin removal.

DO NOT apply a bed of silicon to fix basin to benchtop as this will make it difficult in the future to replace basin.

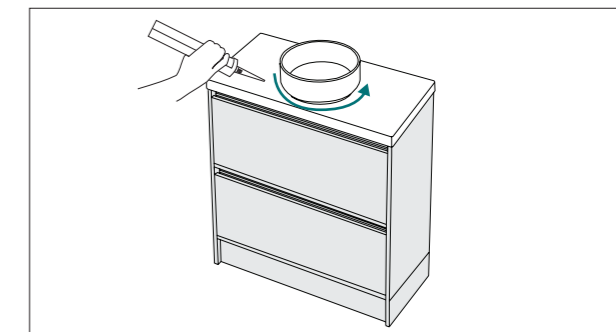

Once basin is in final position and plumbing is finished, put a bead of silicon around the edge to seal and fix in place.

MIRRORED SHAVING CABINET INSTALLATION

Note: If you are installing a light or powerpoint with your mirrored shaving cabinet make sure you consult with your electrician before installing. If the cabinet has easy link brackets please follow the instructions on page 7.

1. POSITION CABINET & LEVEL

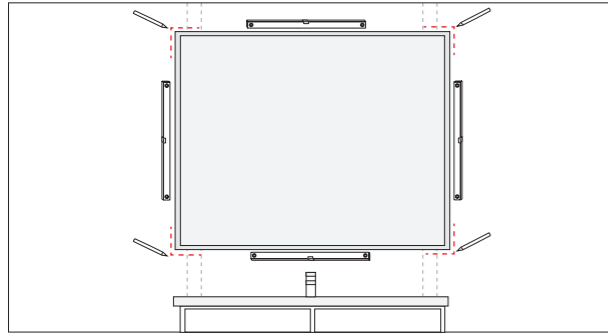

1. Place cabinet on flat surface to remove mirrored doors. Remove doors and place flat on soft surface with mirrors facing up to avoid damages.
2. Locate support beams and position unit in desired location and check all sides are sitting level.
3. Mark the position of the cabinet on all four corners of cabinet

Note: Damage during installation is not covered under ADP warranty.

2. SECURING THE CABINET

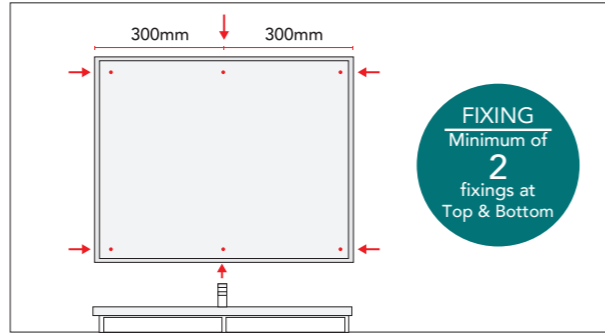

Securely fasten cabinet to the wall through back with appropriate screws/bolts at TOP and BOTTOM of cabinet. Evenly space apart the horizontal fixings at a maximum of 300mm apart.

Note: Where a stud or support beam cannot be located, use an appropriately sized hollow wall anchor.

3. SEALING

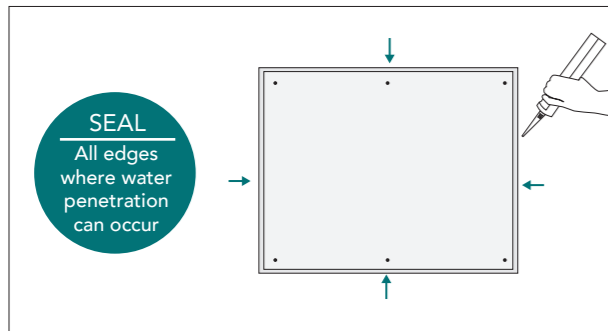

Apply non-acidic silicone to all edges where cabinet meets the wall.

Note: Gap sealant can be used in place of silicone where the unit meets tiled surfaces.

4. ADJUST DOORS

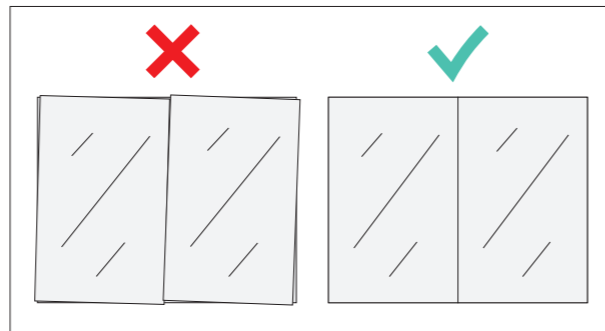

Install doors back onto cabinet and make adjustments to align the doors correctly. See pages 13 for instructions.

NOTE: IT IS THE RESPONSIBILITY OF THE INSTALLER TO MAKE ANY ADJUSTMENTS TO DOORS AFTER INSTALLATION.

OPTION: WHEN RECESSING A MIRRORED SHAVING CABINET

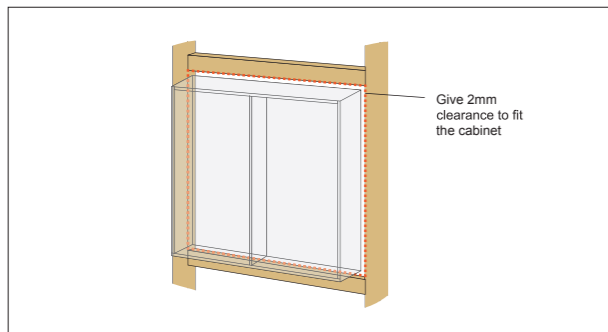

Complete Step 1, cut a hole 4mm bigger than the overall cabinet carcass in the wall. Position and secure cabinet in cut out, go to Step 2.

Note: Make sure the hole has sufficient noggings to fix top and bottom of carcass.

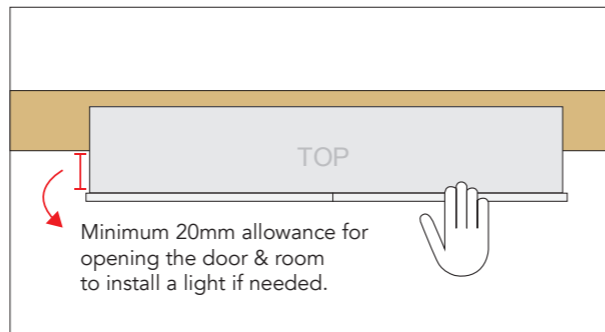

Ensure the cabinet carcass protrudes by a minimum of 20mm from the wall (including tiles) to allow for finger pull on the door.

TALLBOY & ENSEMBLE INSTALLATION

Note: If the cabinet has easy link brackets please follow the Easy Link Bracket Installation Instructions at bottom of page.

1. POSITION CABINET & LEVEL

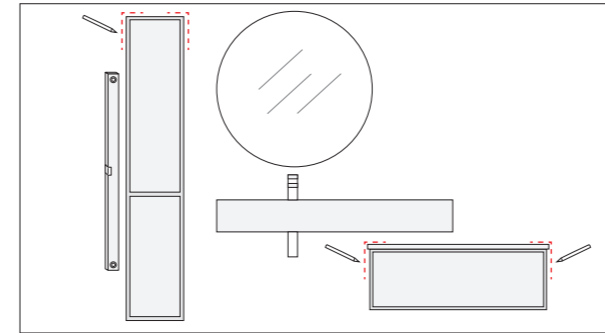

1. Remove all doors and drawers.
2. Position unit in desired location and check all sides are sitting level.
3. Mark the position of the top of the cabinet.

2. SECURING THE CABINET

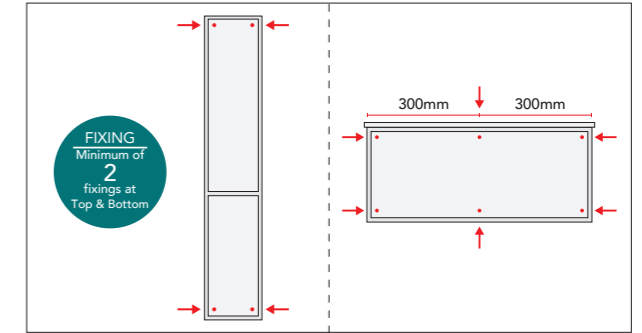

Securely fasten cabinet to the wall through back with appropriate screws/bolts at TOP and BOTTOM of cabinet. Evenly space apart the horizontal fixings at a maximum of 300mm apart.

Note: Where a stud or support beam cannot be located, use an appropriately sized hollow wall anchor.

3. SEALING

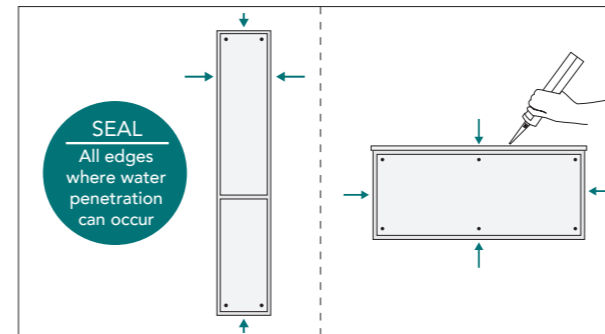

Apply non-acidic silicone to all edges where cabinet meets the wall and floor.

Note: Gap sealant can be used in place of silicone where the unit meets tiled surfaces.

4. ADJUST DOORS & DRAWERS

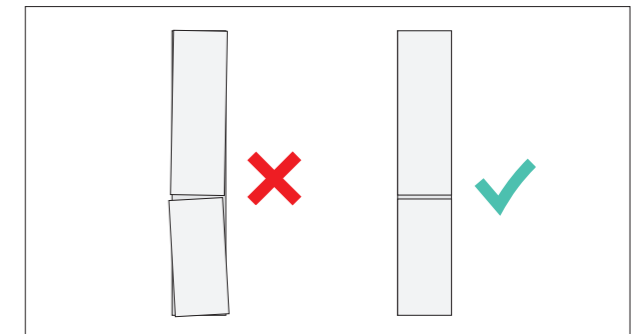

Install drawers and doors back onto cabinet and make adjustments to align the doors and drawers correctly. See pages 8 -13 for instructions.

For Detachable Kickboard Installation refer to page 5.

EASY LINK BRACKET INSTALLATION

If your cabinet or mirror is fitted with easy link brackets, please follow these instructions:

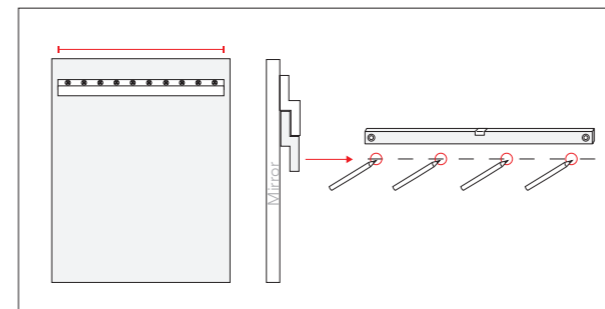

1. Measure location of easy link bracket on back of mirror or wall storage.
2. Mark location of bracket on wall, ensuring it is level.
3. Place wall bracket on the level line and mark screw locations (minimum of 4 screws, 1 going into stud).

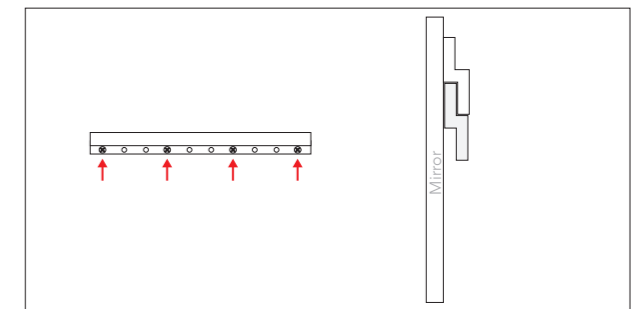

4. Pre-drill through hole locations into wall with appropriate drill bit.
5. Securely fasten wall bracket with appropriate screws through pre-drilled holes.

Note: Once bracket is secure place mirror/wall storage onto bracket. **Note:** You may require different wall fixings depending your wall material (brick etc). Wall fixings not included.

UNIVERSAL PLUG & WASTE INSTALLATION

Note: All plumbing components must be installed by a licensed plumber.

TO INSTALL

- 1) Remove washers and removable plug (A) & check waste fits in hole.
- 2) For ceramic basins - Place thin foam washer (C) in position under rim of Waste Neck (B) & seal in place with a **non-acidic silicone**. For all other basin material types, you do not need foam washer (C) before sealing in place.
- 3) Insert into centre of waste hole.
- 4) Insert Rubber Washer (D) on top of section (E) and screw on (**hand tight only**).
- 5) Insert Removable Plug (A) into the Waste Neck (B), ensuring you align the grooves until the waste is seated & locked into place.

Please Note: Ensure Rubber Seal (A.2) and O-Ring (A.3) are installed on Removable Plug (A) in order to provide a watertight seal.

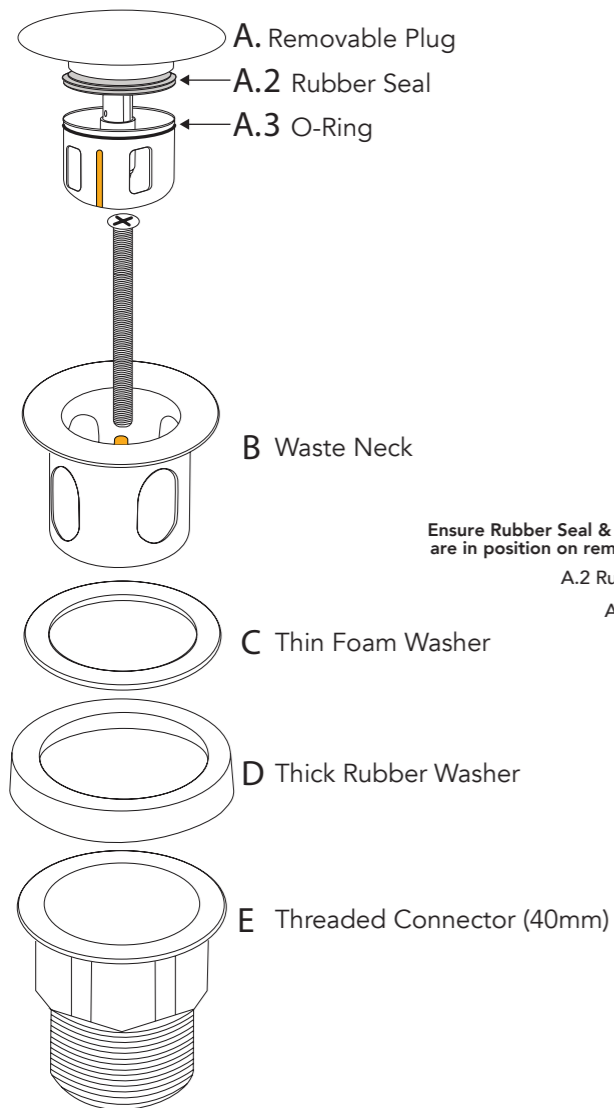

IMPORTANT
 Avoid overtightening waste to prevent stress & damage to the basin or top
HAND TIGHTEN ONLY
 Must be sealed with **NON-ACIDIC** silicone sealant

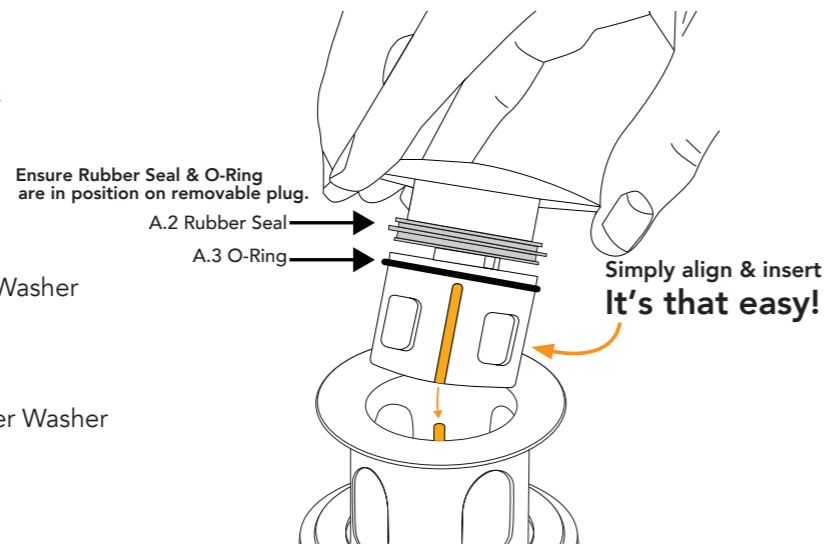

SPACE SAVER PLUMBING KIT

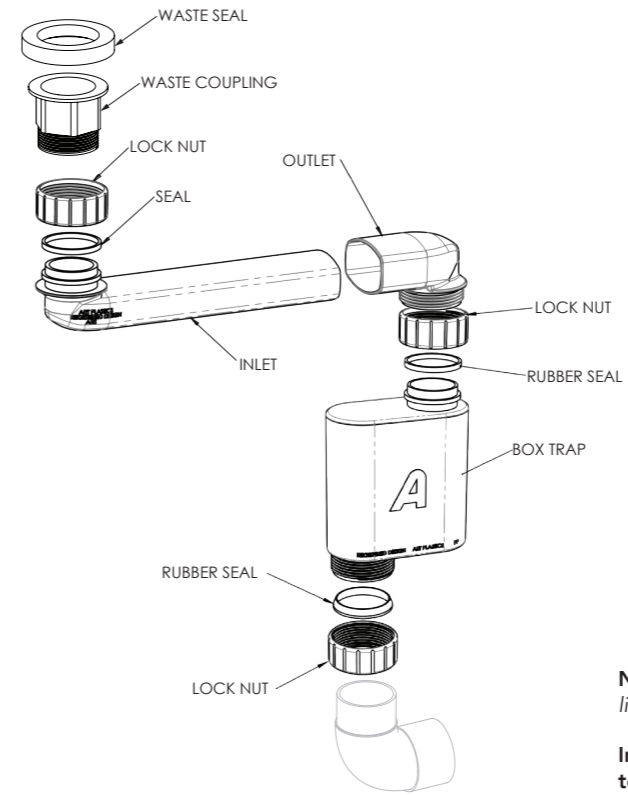

Note: All plumbing components must be installed by a licensed plumber.

Inlet (Pipe) can be cut down to a minimum length of 90mm, to accommodate for smaller spaces.

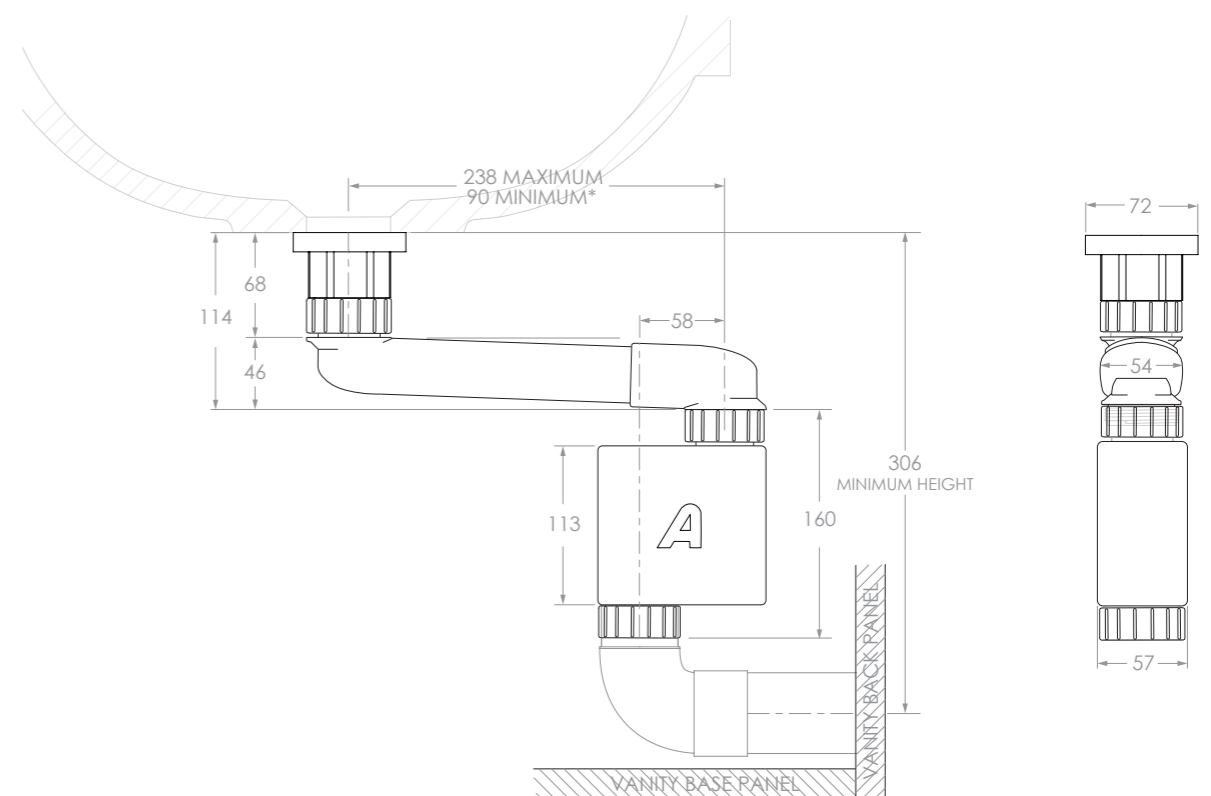

⚠️ DRAWER INSTALLATION & ALIGNMENT

IDENTIFY DRAWER TYPE

Identify what drawer system the cabinet has and then follow the corresponding instructions. If you need help identifying your drawer type or cannot find the drawer system in this booklet please go to www.adpaustralia.com.au or call us on (02) 4271 2444.

PRESSED METAL (PAGE 15)



Note: The drawer sides could be white or grey metal.

PREMIUM SOLID OR LED FROSTED GLASS (PAGE 16)



Note: The drawer sides could be white, graphite or LED glass.

DELUXE LED CLEAR GLASS SIDES (PAGE 17)



HETTICH MULTITECH (PAGE 18)



HETTICH INNOTECH (PAGE 19)



Note: The drawer sides are available in white or graphite finish.

HETTICH AVANTECH (PAGE 20)



🔧 PRESSED METAL DRAWERS

DRAWER HEIGHT ADJUSTMENT

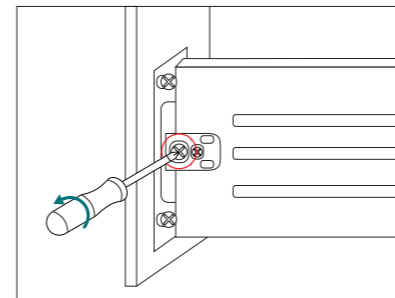

Loosen the front screw.

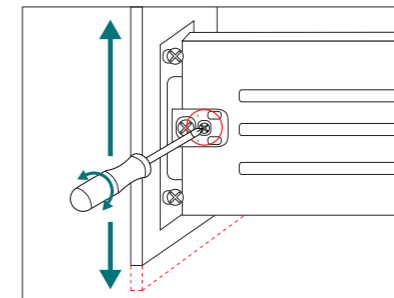

Turn the back screw to adjust the height of the drawer front. Turn anti-clockwise to go up and clockwise to go down.

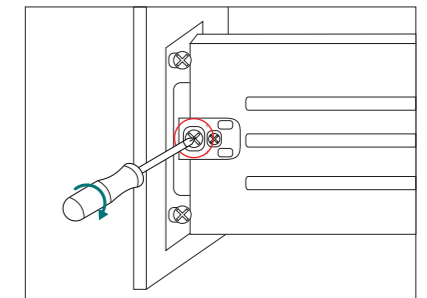

When drawer height is aligned, tighten the front screw. Repeat on both sides of drawer if needed.

DRAWER LATERAL ADJUSTMENT

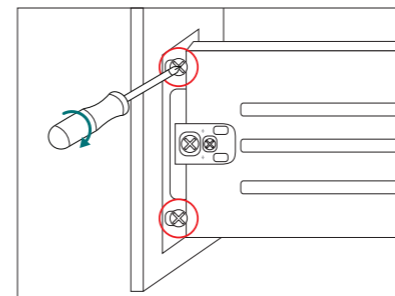

Loosen top and bottom screws on both sides of drawer.

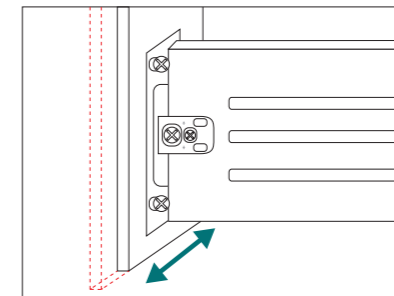

Slide drawer front left or right.

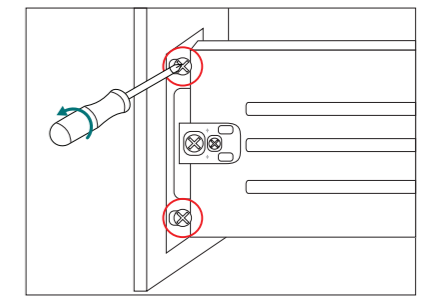

When drawer front is aligned, tighten all screws in place.

REMOVING & INSERTING DRAWER

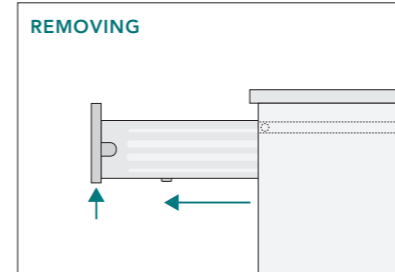

Slide drawer out, lift up and out to remove.

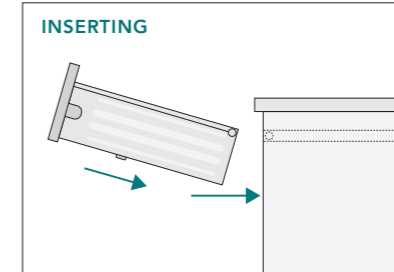

Insert drawer on an angle. Align top of metal sides onto runners in cabinet and push into place.

DRAWER FRONT REMOVAL AND INSTALLATION

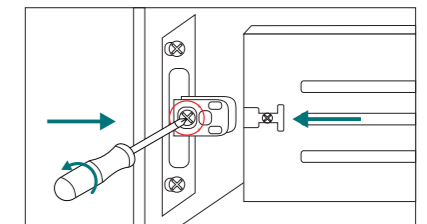

To remove drawer front: Loosen front screw on both sides until drawer front comes off.

To install drawer front: Align drawer front with sides of drawer and tighten front screw to secure in place.

TROUBLESHOOTING - HOW TO RE-ENGAGE THE SOFT-CLOSE ADAPTER

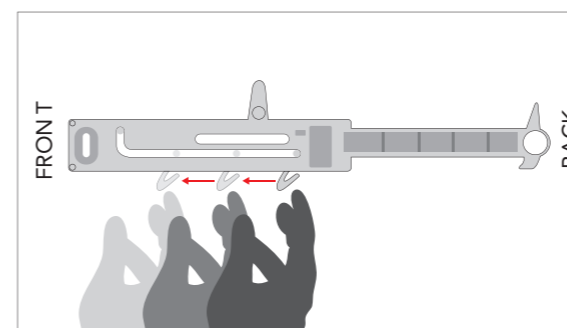

Soft-close not working?

1. Remove drawer.
2. On inside of cabinet, re-set the trigger by pulling the tab towards the front of the cabinet.
3. Insert drawer and the soft-close should re-engage.

Note: If this does not solve the problem, your cabinet may not be level or plumb as there could be an alignment issue.

PREMIUM SOLID OR LED FROSTED GLASS DRAWERS

REMOVING & INSERTING DRAWER

REMOVING

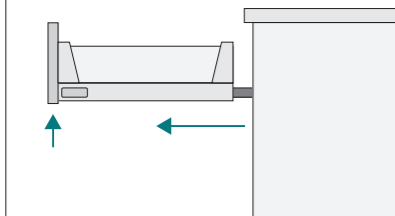

Pull drawer all the way out then lift the front up, a little force is needed to release the drawer from the runner.

INSERTING

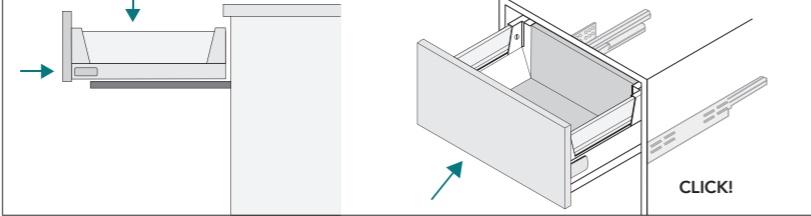

Extend drawer runners out and place drawer on runners and push closed until it is about 2cm out from the vanity. Apply a little extra force on the drawer front (near the bottom of drawer) to push closed

and connect runners in place. The drawer should then be automatically connected to the runner by the two catches. Listen for a click!

DRAWER HEIGHT ADJUSTMENT

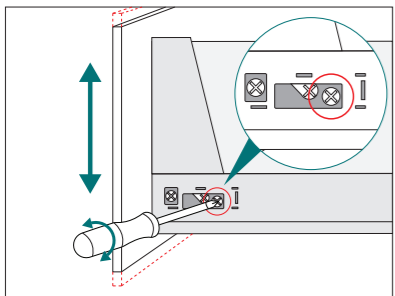

Remove ADP cap to access screws. Turn the back screw to adjust the height of the drawer front. Turn clockwise to go up and anti-clockwise to go down.

LATERAL ADJUSTMENT

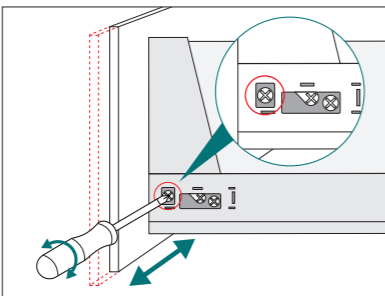

To move drawer front to the right, turn right screw clockwise and left screw anti-clockwise. Turn the opposite way to move to the left.

TILT ADJUSTMENT

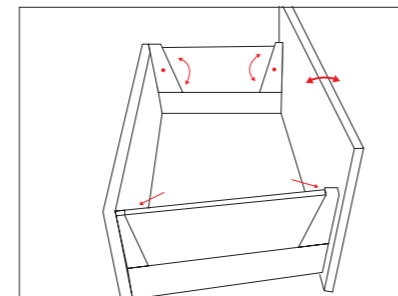

To tilt drawer front, turn adjustment screws on inside of drawer at the front and back, on both sides.

DRAWER FRONT REMOVAL AND INSTALLATION

First you will need to remove the Solid or LED drawer side:

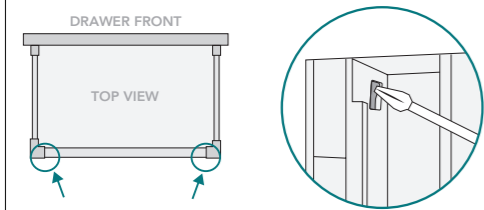

Identify plastic lugs - lugs are at the back of the drawer on each side at the top.

With a screw driver push into the lug to release the side and start pulling up.

Pull the drawer side up and off with both hands, sliding off the fixing brackets. Repeat on both sides.

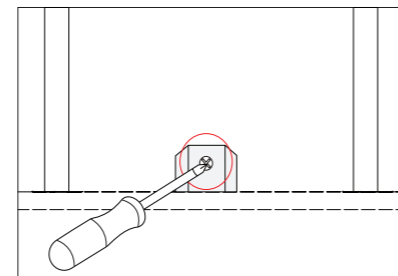

Depending on width of drawer you may need to unscrew and remove middle bracket on the under side of the drawer.

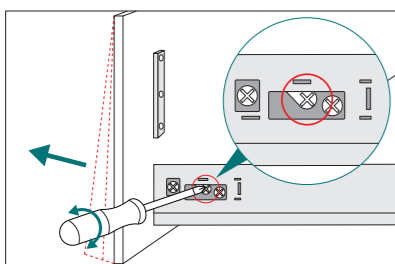

To remove drawer front: Turn centre screw and pull drawer front forwards. Repeat on other side.

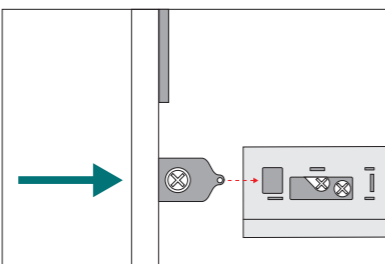

To replace drawer front: Align front panel with drawer sides, apply some pressure at the bottom on both sides and push in to secure.

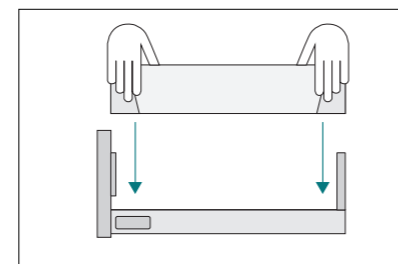

Slide the drawer sides down onto the fixing brackets until the lug secures side in place. Repeat on both sides.

DELUXE LED CLEAR GLASS DRAWERS

REMOVING DRAWER

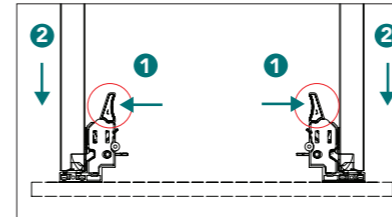

Pull drawer out and squeeze both levers in on the underside of the drawer, at the same time (to activate release) and pull drawer out to remove.

INSERTING DRAWER

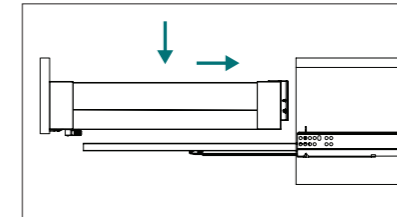

Extend drawer runners out and place drawer on runners. Push drawer closed until it is about 2cm out from the vanity.

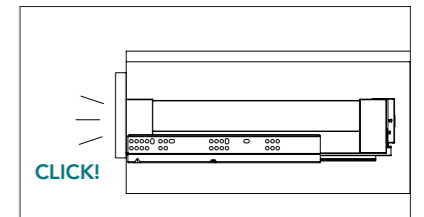

You will then need to apply a little force on the drawer front (near the bottom) to push closed and connect runners in place.

LATERAL ADJUSTMENT

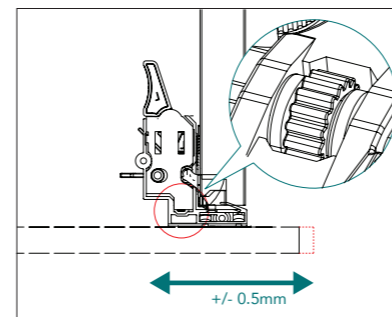

DEPTH ADJUSTMENT

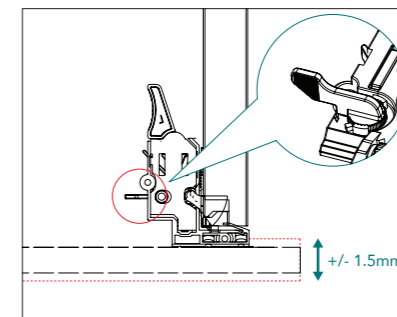

HEIGHT ADJUSTMENT

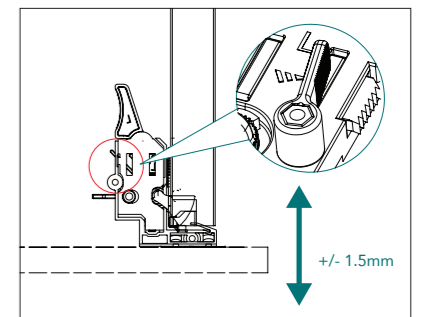

DRAWER FRONT REMOVAL AND INSTALLATION

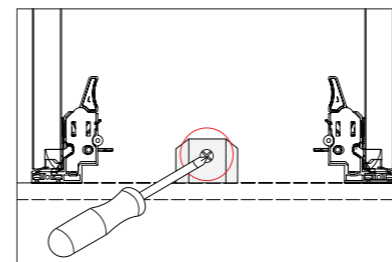

Depending on width of drawer you may need to unscrew and remove middle bracket on the under side of the drawer.

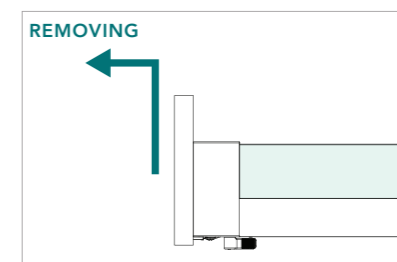

Hold drawer side *down* as you lift drawer front *up* to slide drawer front up and off. You will need to do this to both sides.

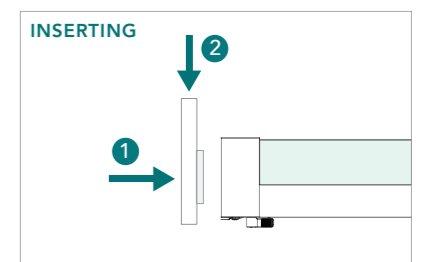

1. Line up the brackets on the drawer front with drawer sides.
2. Slide drawer front down to secure in place.

BATTERY PACK INSTALLATION

BATTERY PACK INSTRUCTIONS FOR LED FROSTED GLASS DRAWERS AND DELUXE LED CLEAR GLASS DRAWERS

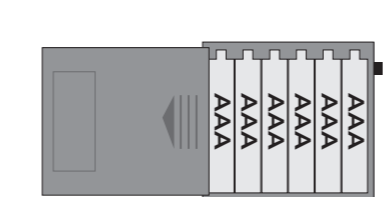

6 x AAA batteries are required for the battery pack. Slide the cover plate off, insert batteries and slide cover plate back on.

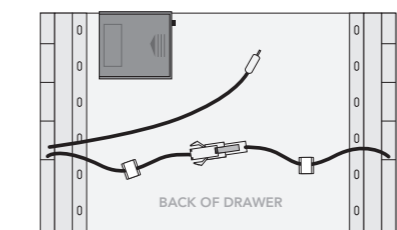

On the back of the drawer attach the supplied battery pack on the top left hand side over the back panel.

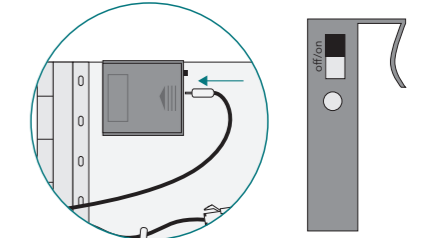

Plug the cord into the side port of the battery pack. Turn the switch to the 'ON' position. The LED lights in the drawer sides should switch on.

REMOVING DRAWER

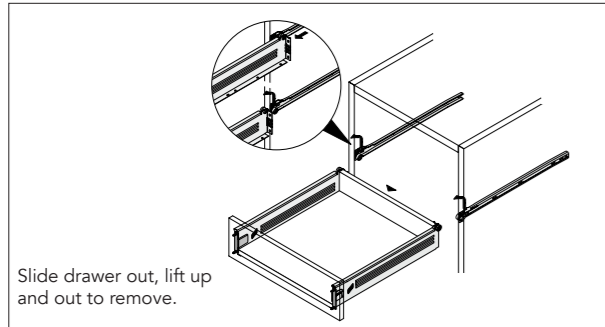

Slide drawer out, lift up and out to remove.

INSERTING DRAWER

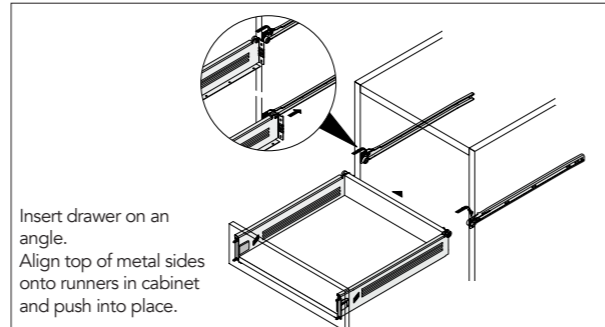

Insert drawer on an angle. Align top of metal sides onto runners in cabinet and push into place.

HEIGHT ADJUSTMENT

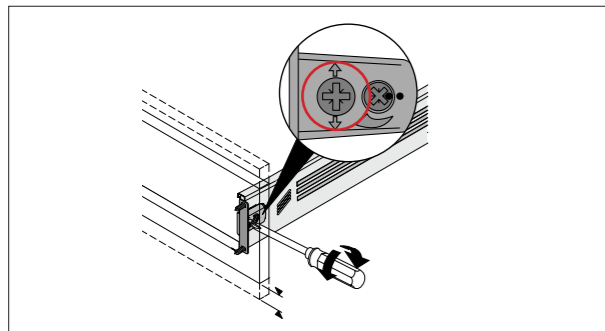

LATERAL ADJUSTMENT

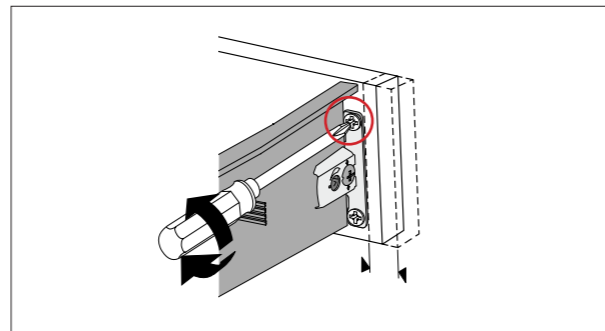

DRAWER FRONT REMOVAL

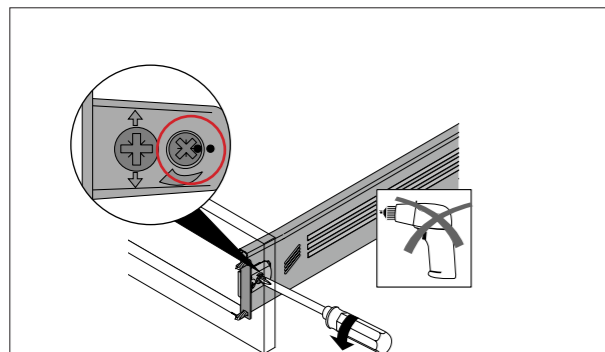

Loosen back screw on both sides until drawer front comes off.

DRAWER FRONT INSTALLATION

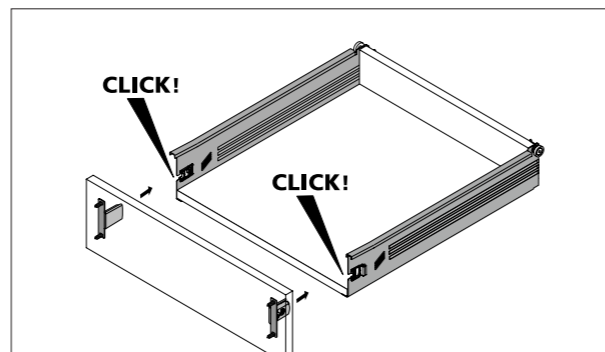

Align drawer front with sides of drawer and tighten front screw to secure in place.

REMOVING DRAWER

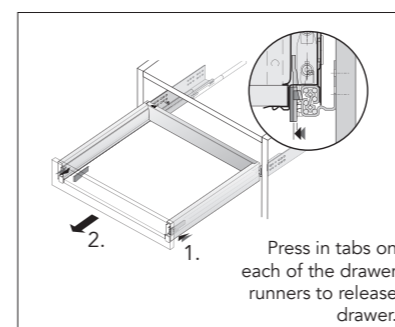

Press in tabs on each of the drawer runners to release drawer.

INSERTING DRAWER

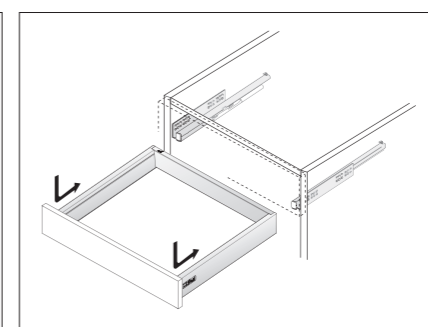

REMOVING/INSTALLING COVER

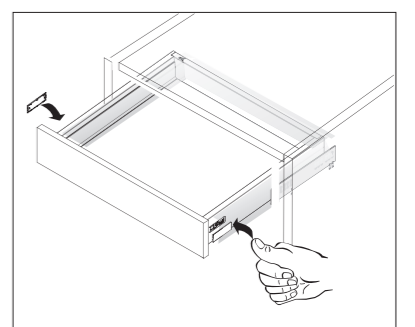

HEIGHT ADJUSTMENT

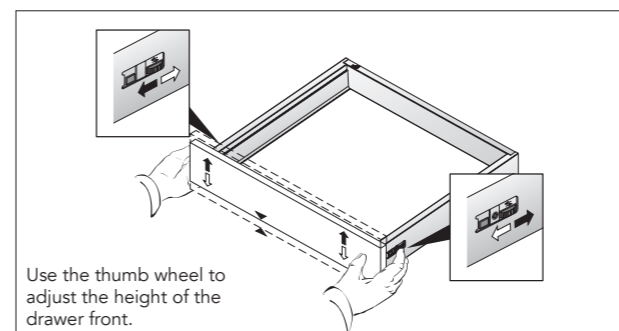

Use the thumb wheel to adjust the height of the drawer front.

LATERAL ADJUSTMENT

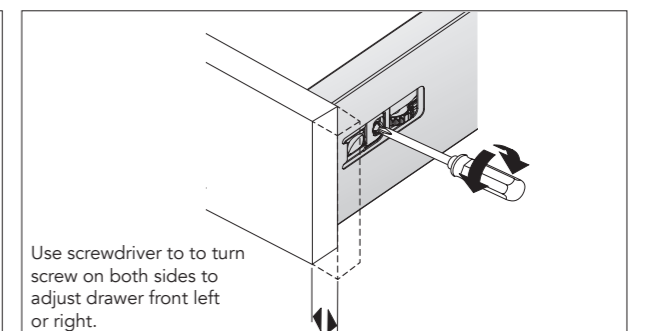

Use screwdriver to turn screw on both sides to adjust drawer front left or right.

TILT ADJUSTMENT

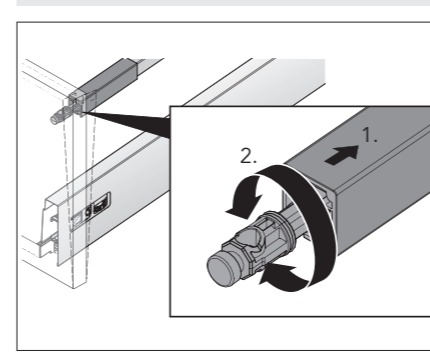

RAILING REMOVAL

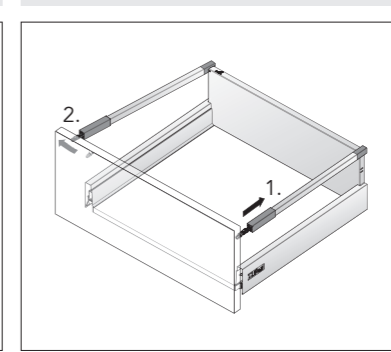

RAILING INSTALLATION

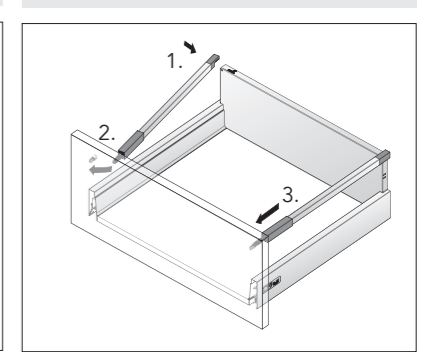

DRAWER FRONT REMOVAL

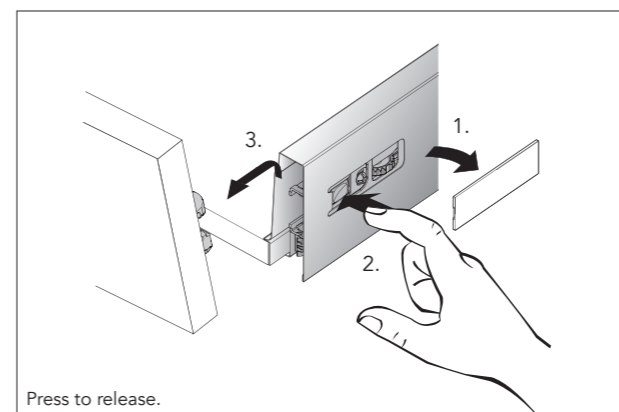

Press to release.

DRAWER FRONT INSTALLATION

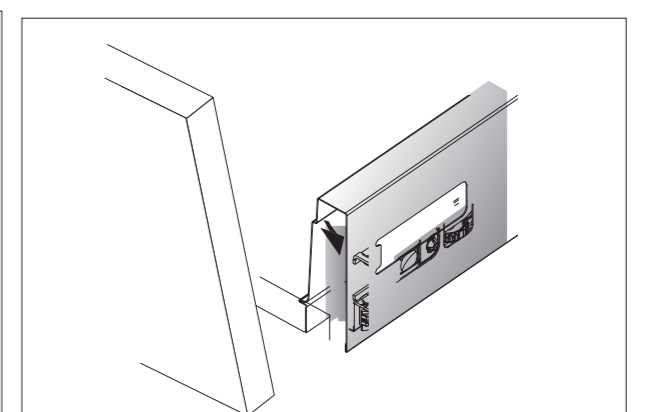

REMOVING DRAWER

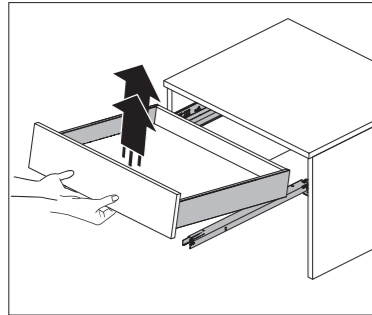

INSERTING DRAWER

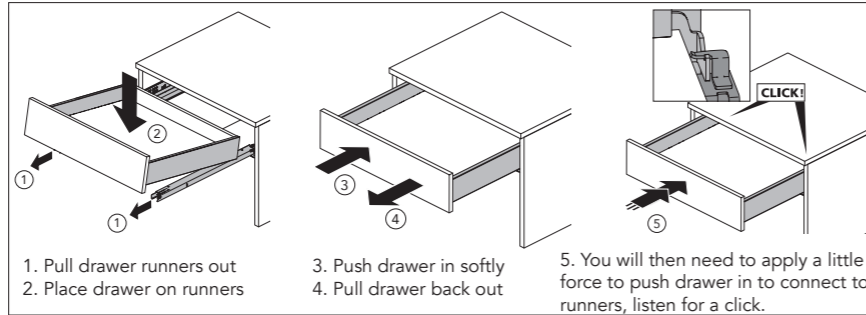

SLIDE DRAWER COVER

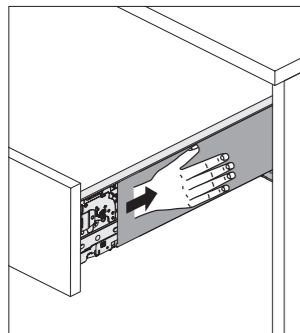

HEIGHT ADJUSTMENT

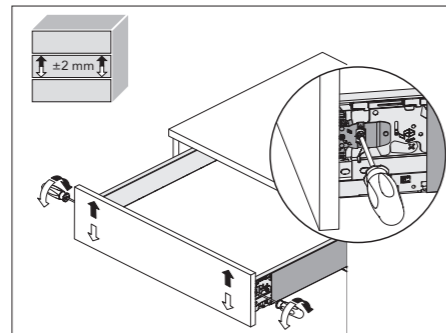

LATERAL ADJUSTMENT

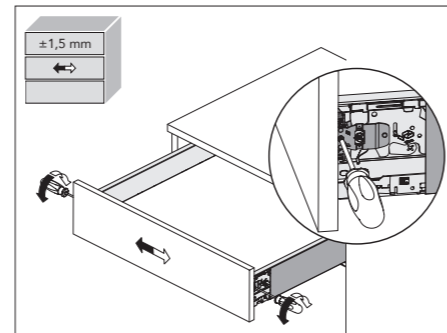

TILT ADJUSTMENT

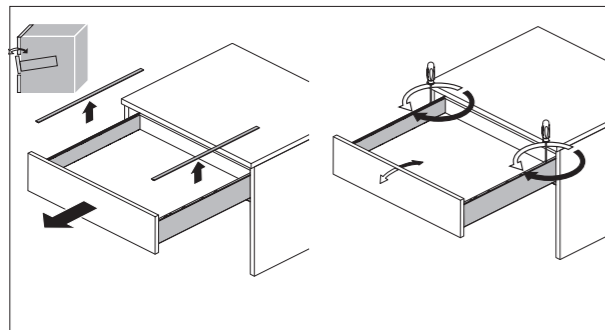

DEPTH ADJUSTMENT (FOR PUSH-TO-OPEN ONLY)

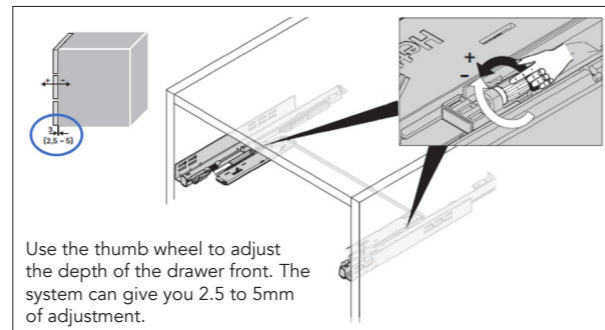

DRAWER FRONT REMOVAL

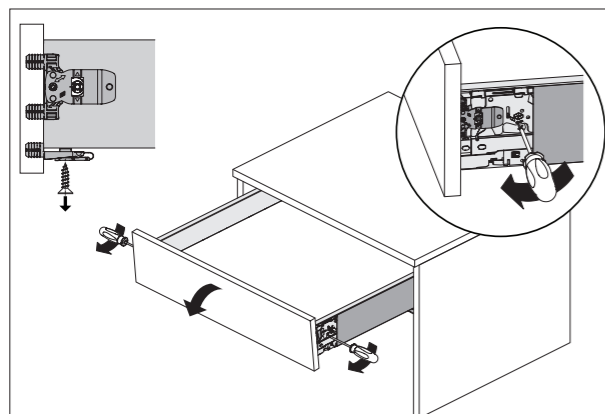

DRAWER FRONT INSTALLATION

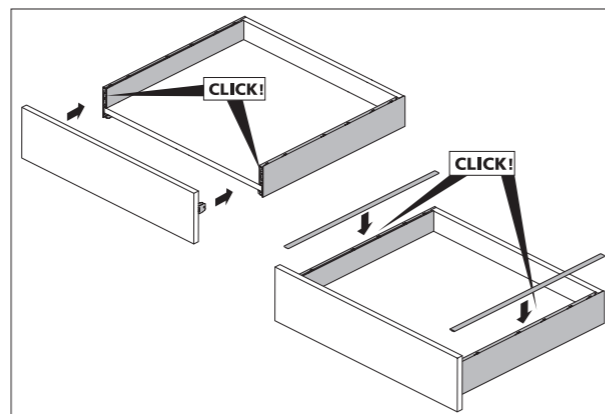

SIDE ADJUSTMENT

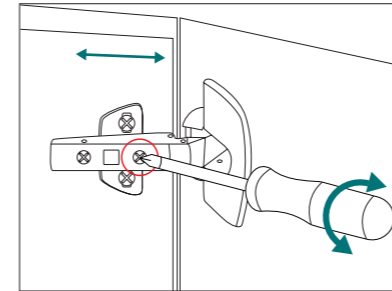

Use front screw to move door to the left or right, or to level each door.

DEPTH ADJUSTMENT

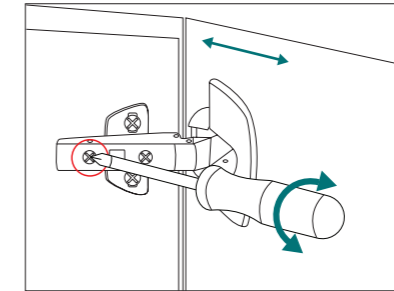

Use back screw to move door inward or outward from carcass.

HEIGHT ADJUSTMENT

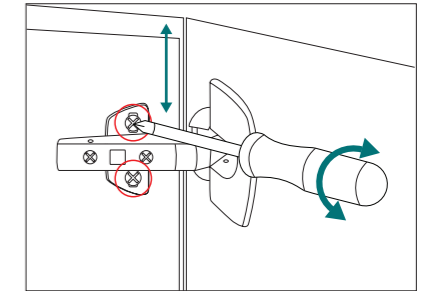

Loosen the top and bottom screw on mount plate, adjust door height by moving door up or down, then retighten screws.

DOOR HINGE INSTALLATION

REMOVING & INSTALLING DOORS

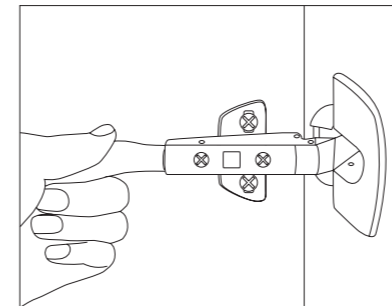

TO REMOVE DOORS:

Apply finger pressure to clip at back of hinge and pull forward to release.

TO INSTALL DOORS:

Align door hinge with hinge mount on carcass, press back of hinge into place and listen for a 'click' to lock the hinge in place. You may need to apply a little force to lock the hinge in place.

REMOVING HINGE FROM DOOR

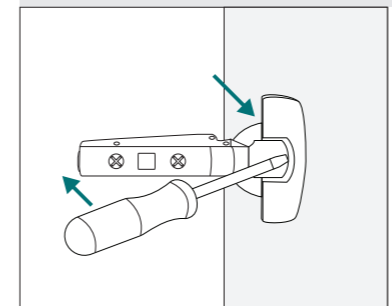

Once you have removed door from the cabinet, using a flat head screw driver, lift and release the top cover plate.

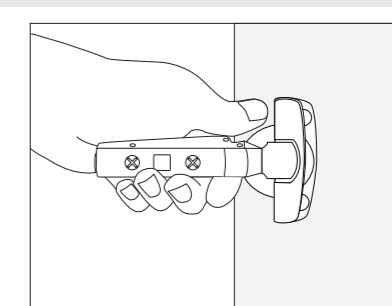

Pull hinge up and out from door. You may need to wiggle the hinge to loosen and use a little force.

REPLACING HINGE ON DOOR

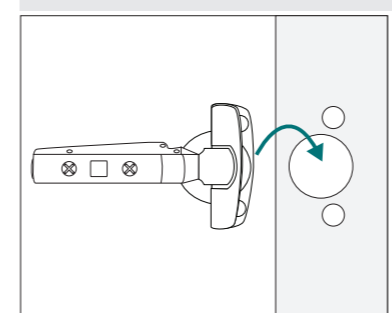

With top cover plate lifted, place hinge into position on door and insert into holes until flush.

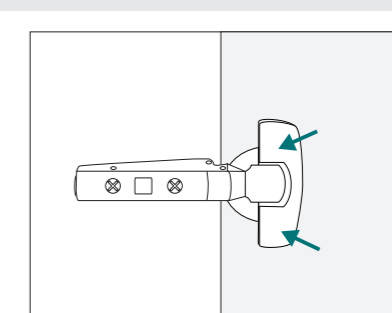

Once secured in position, click cover plate down to lock into place.

HAMPER INSTALLATION & ADJUSTMENTS

PARTS INCLUDED

OVERALL DIMENSIONS

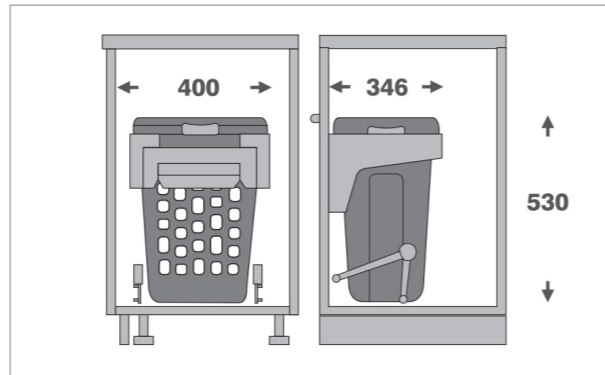
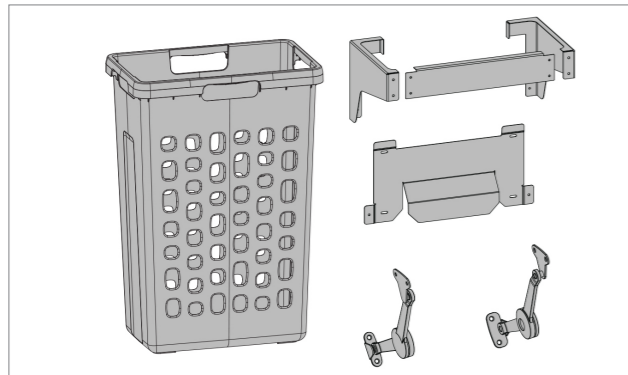

BRACKET

ARMS

HINGES

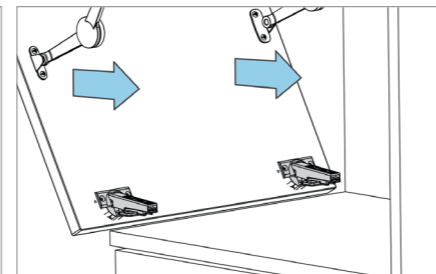
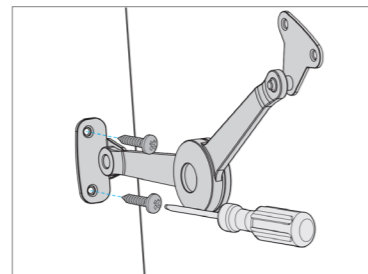
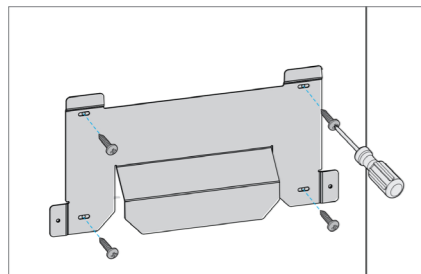

Screw bin tray bracket to the door.

Screw both soft close arms to door.

Mount the hinges to the door as per the instructions on previous page (page 20).

ADJUSTMENTS

ATTACH ARMS

ASSEMBLY

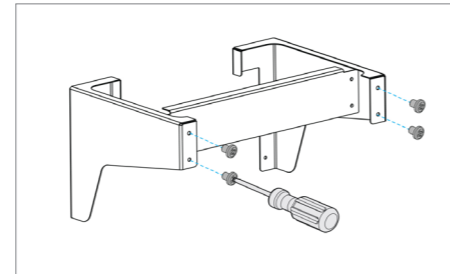
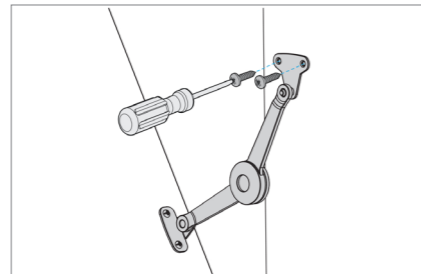
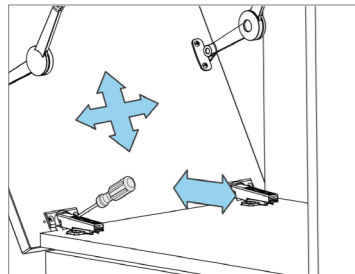

Make door adjustments using the lower hinges.

Screw both soft close arms to cabinet.

Assemble bin tray parts.

BRACKET

BRACKET

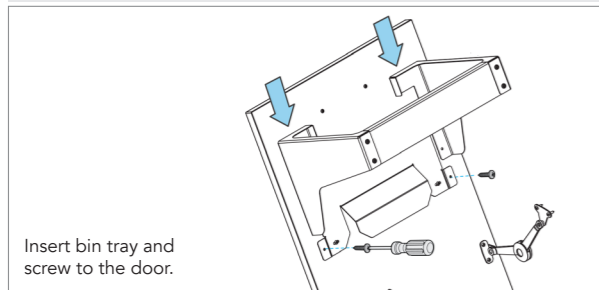

Insert bin tray and screw to the door.

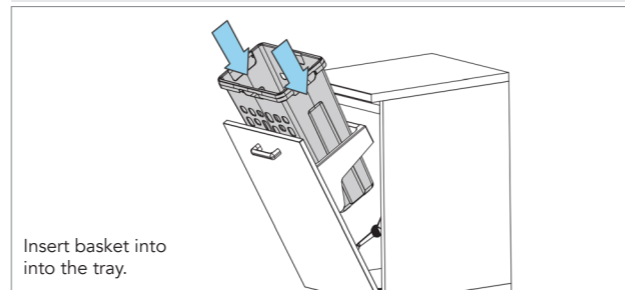

Insert basket into into the tray.

Note: Hamper door adjustments, made using bottom hinges. See left page (pg. 20) for adjustment instructions.

ELECTRICAL STANDARDS & GUIDELINES

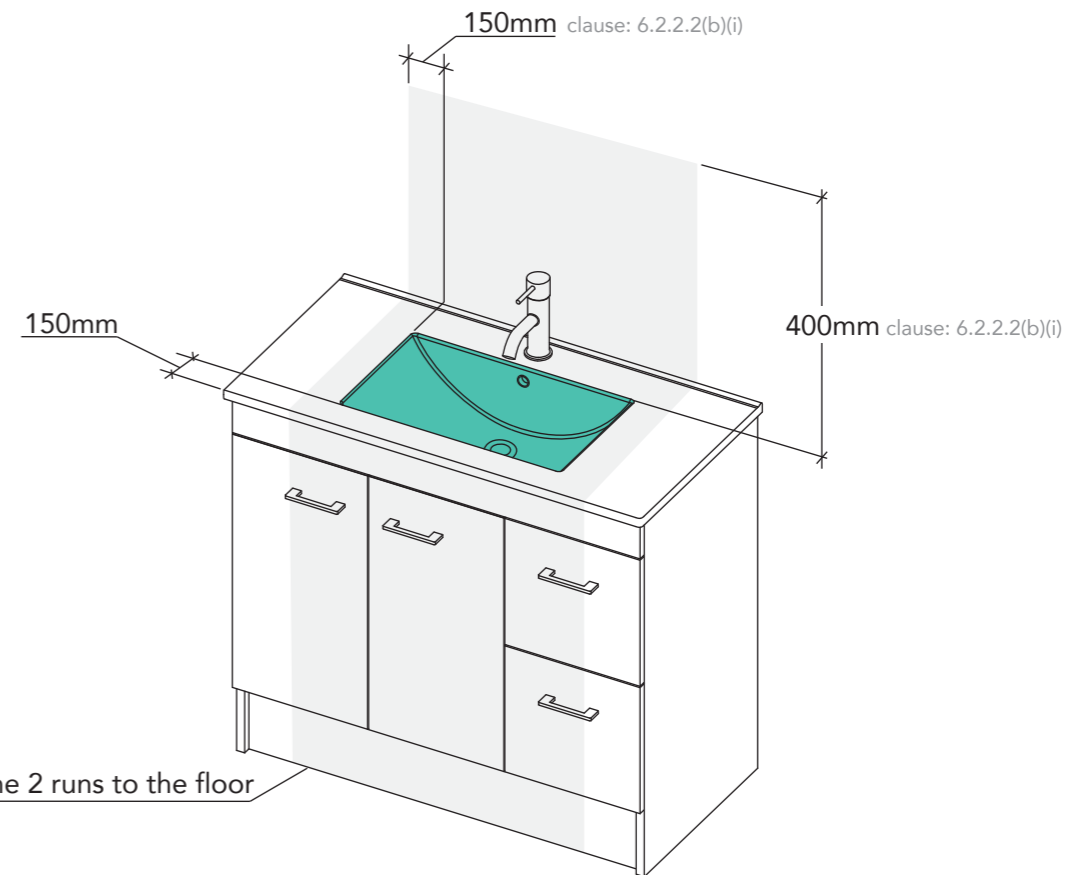

ZONE	AREA	ELECTRICAL ALLOWANCES
0	This is a fixed water container with a capacity not exceeding 45L, such as a basin or vessel	No sockets or lights in this area. clause: 6.2.4.2(a)
2	This is a measured area outside of the fixed water container.	Sockets are allowed if it is a shaver outlet complying with AS/NZS314. clause: 6.2.4.2(b)(i) An RCD protected power point enclosed within a closed cupboard. clause: 6.2.4.2(b)(ii) IP44 LED lighting (ELV - Extra Low Voltage) with the controller positioned outside of Zone 2. clause: 6.2.4.4(b)(ii)
Outside of zone 0 and 2		You can have sockets and lights, all must be RCD protected to meet the reqs of clause: 1.5.5.2. The back of the socket needs to be protected, for example a case on the back of a socket installed on a drawer to meet clauses: 1.5.1,1.5.3,1.5.4.

Please take care of me

Care & Maintenance Guide

Tips

- ADP products are produced from materials that are well suited to the bathroom, however it is important that your bathroom has sufficient ventilation to avoid excessive moisture. High humidity will lead to permanent dampness and mould, resulting in deterioration of the materials.
- Care must always be taken to dry any excessive moisture or water spillage.

Cabinets

- To maintain the finish on your cabinet use only a soft cloth and weak solution of non abrasive detergent.
- To remove scratches, marks, etc. on two pack polyurethane, rub gently with car cutting compound, car polish or household brass/silver cleaner.
- Goods used in construction are water/moisture-resistant, but not water-proof.
- All cabinets should be installed at least 300mm away from showers or bathtubs to avoid water damage.

Cast Marble & Acrylic

- To maintain the finish on your Cast Marble or Acrylic top use only a soft cloth and weak solution of non-abrasive detergent.
- To remove scratches, marks, etc. rub gently with car cutting compound, car polish or household brass/silver cleaner.

Ceramic Basins & Tops

- To maintain the finish on your ceramic top use only a soft cloth and weak solution of non abrasive detergent.
- Due to the glazed surface of ceramic tops, scratches cannot be repaired or removed.
- Due to ceramic being a handcrafted product that is fired at high temperatures, some visual distortion may occur. This is not a defect but can be seen to add to the beauty of the product.

Solid Surface, Cherry Pie, Durasein, Caesarstone

- Wipe clean with a soft damp cloth or sponge.
- For basic stains clean with mild detergents. For **gloss and semi-gloss** surfaces you can use a non abrasive polish or Brasso. For **matte** surface use a scourer pad or scotch bright to maintain the matte finish.
- Cherry Pie, Durasein and Caesarstone benchtops have excellent heat and chemical resistant properties compared to other surfacing products, however to preserve the surface and protect against damage from heat, do not place hot items directly on the surface. Even though Cherry Pie, Durasein and Caesarstone can withstand high temperatures, prolonged periods or extreme heat can cause permanent damage.

Mirrors

FOR BEST RESULTS

Use a slightly moistened microfibre cloth to remove dry dirt or grime, then buff clean with dry microfibre cloth or use a soft dry cloth with a tight weave (which is more soft and non-abrasive). This will leave you with a clean, smear-free finish. By using alkaline (ammonia) or acid (vinegar) based products you not only risk damaging the silvered backing of the mirror, but also tend to leave behind streaks and smears.

DO NOT

Do Not use ammonia-based cleaning products such as glass cleaner. These may erode the mirror's silver backing. Be sure to read the label of any such cleaning products before use.

PROTECTION AGAINST 'BLACK-SPOTTING'

Alkaline, acid and moisture elements can cause the silvered backing of a mirror to darken, this is usually referred to as 'black-spotting'. An easy way to protect your mirror against black-spotting is to regularly oil any exposed edges (i.e. polished or bevelled edges), using non-petroleum based oils (eg. sewing machine oil). This will act as a seal to protect against such elements. Always remember to keep your mirror dry and wipe off any water, moisture or steam.



If you cannot identify basin, top or cabinet material of your product, contact your merchant or see product information at www.adpaustralia.com.au.

Let's talk bathroom ventilation

Good bathroom ventilation will save you thousands of dollars and keep your family healthy - mould can be a huge problem in bathrooms if they're not properly ventilated.

We've broken down everything you need to know about ventilation with a handy guide.



Scan to watch a quick 3 minute video with our top bathroom care and maintenance tips to ensure you get years longer out of your bathroom products!

Why ventilation is so important



It's crucial to have the best ventilation possible for your bathroom as moisture can be the root of all wet area products breaking down and failing, in particular your vanity and mirror. These products are usually water resistant not waterproof so it's important moisture does not build up which will mean your products will last longer, saving you money!

Good ventilation is also key to achieve lower humidity in the room which will minimize bacteria growth and prevent mould and mildew. You'll have less mildew on your grout, walls and ceilings, and fewer mould spores to threaten your respiratory health.

So why wouldn't you keep your bathroom well ventilated!

Signs of poor ventilation



The earliest sign to look out for is black spotting on mirrors.

When the steam or humidity rises to the top of the room and ventilation is not sufficient, the mirror (which is normally positioned high up in the room) is the first thing to steam up. Over time, this causes damage to the mirror that appears as black spots or corrosion which cannot be reversed.

Other signs might include paint starting to flake on the ceiling, bubbling of paint coatings on fixtures, and furniture swelling.

Evidence of mould or mildew is also a good indicator that your ventilation is not adequate.

How to achieve good ventilation



The best sign that your ventilation is sufficient is that the mirror doesn't steam up and the tiled walls aren't wet.

The best way to achieve this is to have a good exhaust fan that is correctly sized for the space, to do this you need approximately 50 cfm per toilet and 50cfm per shower or bath. The fan should be installed to exhaust air into a duct that directs the air outdoors, not into your walls. Using the wall joists to guide exhaust air can result in moisture and mould problems in the walls.

Run the fan every time water is being used in the bathroom and run it for around 15 minutes after you shower.

If you have a bathroom window, opening that daily (even in the chilly winter months) in addition to using the exhaust fan will help to keep your bathroom fresh and mould-free.

We hope you enjoy your well ventilated, mould-free bathroom for many years to come!

A note about your vanity top or basin

I'm unique

Thank you for purchasing our product. We just wanted to let you know a few things about your new product.

Your vanity top or basin is a handcrafted product that has endured high temperatures during the manufacturing process, some size variation and visual distortion is to be expected. This is not a defect but can be seen to add to the aesthetics of the product.

Due to the nature of the manufacturing process, every item is unique. Please be assured that slight surface variances and size tolerances are normal. We have a thorough quality control process that ensures the finished product meets quality guidelines and is as close to the nominal specifications as possible.

Here at ADP, we take pride in delivering quality products and are committed to a sustainable future.

Please take care

So you can enjoy your vanity top/basin for many years to come, care must be taken.

Some materials are more heat and scratch/chip resistant than others, to preserve the surface and protect against heat damage do not place hot items directly on the surface. Avoid dropping heavy or sharp objects on surfaces as scratching and chipping may occur.



Wipe, Rinse, Dry

Keep it simple for everyday cleaning.

Wipe gently with a warm and soapy damp cloth or sponge, using a mild detergent.

Rinse off with clean water.

Dry with a soft towel or microfiber cloth for an impeccable finish!



TROUBLESHOOTING

PROBLEM	LIKELY CAUSE	SOLUTION
I have noticed damage to my product, should I install it?		No - advise the store you purchased the product from before installation.
Where can I find specifications or more information for the product I have purchased?		Go to www.adpaustralia.com.au . If you still can't find what you're looking for, call us on (02) 4271 2444.
My cabinet doors are out of alignment.	There may have been some movement in transportation and installation which causes doors to become unaligned.	Follow the hinge adjustment instructions on page 13 to align doors.
My cabinet drawers are out of alignment.	There may have been some movement in transportation and installation which causes drawers to become unaligned.	Identify drawer type (page 8) and follow the corresponding instructions to adjust and align drawer.
My drawer is not closing properly.	Incorrect installation, debris in the drawer runners or an obstruction preventing the drawer from closing.	<ul style="list-style-type: none"> - Check the drawer box has been installed correctly (page 8). - Check the cabinet has been installed correctly (eg. is it level & plumb?). - Check there is no debris in the drawer runners and vacuum out if there is. - Check there is nothing obstructing the drawer (eg. plumbing or tap hose).
My metal-sided drawer with soft-close adapter is not working properly?	The soft-close adapter may not be engaged.	Remove drawer. On inside of cabinet, re-set the trigger by pulling the tab towards the front of the cabinet. Insert drawer and the soft-close should re-engage.
I am missing something from my order (eg. vanity bin or basin).		Notify place of purchase of missing parts.
My plug & waste is not sealing / holding water.	<ul style="list-style-type: none"> - Debris build up eg. soap scum, hair etc. - Not installed correctly. - Silicone has not been applied under waste rim, allowing water to escape. 	<ul style="list-style-type: none"> - Pull out the plug (part A) and clean thoroughly, removing any debris. - Ensure the plug is locked in place - push down until you hear a 'CLICK' to provide a watertight seal. See page 8.
I have a stain or mark on vanity top or basin.		Identify benchtop or basin material and see care & maintenance guidelines on page 14 for appropriate cleaning method.

WARRANTY

NOTE: Unless otherwise stated warranties for ADP products are as follows:

PRODUCT	DOMESTIC WARRANTY	COMMERCIAL WARRANTY
Cabinets - Vanities, Tallboys & Ensembles, Mirrored Cabinets (excluding mirror)	10 years (1 year Parts & Labour)	1 year
Cherry Pie / Durasein	10 years (1 year Parts & Labour)	1 year
Acrylic Tops / Cast Marble Tops / Solid Surface Tops	7 years (1 year Parts & Labour)	1 year
Ceramic Moulded Tops	5 years (1 year Parts & Labour)	1 year
Solid Surface Basins	7 years (1 year Parts & Labour)	1 year
Ceramic Basins	1 year (1 year Parts & Labour)	1 year
Travertine Basins	5 years (1 year Parts & Labour)	1 year
Concrete Basins	3 years (1 year Parts & Labour)	1 year
Baths	7 years (1 year Parts & Labour)	1 year
Toilets	10 year (1 year Parts & Labour)	1 year
Mirrors (including mirrored surfaces on cabinets)	1 year (1 year Parts & Labour)	1 year
Hardware	7 years (1 year Parts & Labour)	1 year
Electrical / Lighting / Plumbing Fittings	1 year (1 year Parts & Labour)	1 year
Tapware		
Cartridge	15 years	1 year
Body (against manufacturing faults and flaking)	7 years	1 year
Parts and Labour	2 years	1 year
Bathroom Accessories	7 years	1 year

Our products come with guarantees that cannot be excluded under the Australian Consumer Law. You are entitled to a replacement or refund for a major failure upon inspection by an authorised representative where a product is found to be defective in construction, material or assembly. You are also entitled to have the goods repaired or replaced if the goods fail to be of acceptable quality and the failure does not amount to a major failure, free of charge.

CONDITIONS

1. Items must be installed by a licensed tradesperson.
2. Failure is due to a fault in the manufacture of the product.
3. Proof of purchase is provided.
4. The installation of the product is in accordance with the instructions provided.

Please report any issues with your product within 48 hours of receiving your goods, no claims will be considered after this time. No claims for damages or wrong product will be recognised after installation.

EXCLUSIONS

To the fullest extent permitted by law, the manufacturer excludes all liability for damage or injury to any person, damage to any property and any indirect consequential or other loss or damage. Manufacturer will not be liable for the cost of installation or removal of any unit and the warranty will be VOIDED if damage occurred during or after INSTALLATION or a damaged or incorrect unit has been installed. Door and drawer adjustment; Unsuitable or improper use; Incorrect installation or installation not in accordance with the instructions provided; Installation or part installation by the purchaser or any person other than a LICENSED tradesperson; Normal wear and tear; Inadequate or complete lack of maintenance; chemical, electrochemical or electrical influences; excessive heat damage or Harsh detergents or abrasive cleaners used on product finishes, are NOT considered a warranty issue. **Water damage is not covered under ADP Warranty.** Acrylic, Ceramic, Solid Surface and Bamboo basins and tops have a maximum water temperature of 65°C, Cast Marble has a maximum water temperature of 70°C, water temperatures above this will void warranty.

CLAIM PROCEDURE

For all warranty queries customers are to contact the branch where the product was purchased (these details can be found on your purchase invoice) or go to www.adpastralia.com.au/warranty-support to submit a claim.

WARRANTY

SERVICE CALL OUT FEES & CHARGES

In the event of a call out for issues covered under the ADP manufacturer warranty, no call out fees will apply.

If ADP is called out and the cause of the issue falls within the warranty exclusions or the installation instructions have not been adhered to, the following charges will apply:

Call out fee: \$198.00 initial cost, first 15 minutes included.

Service time onsite: \$24.75 / billed in 15 minute increments.

Call out times: Business hours 9am - 5pm.

Note: Response time will depend on technician availability.

WARRANTY AGREEMENT - HOME OWNER TO KEEP

IMPORTANT: Warranty form to be completed by a licensed qualified tradesperson responsible for the installation of this unit. Any warranty will be VOIDED if unit is not installed by a licensed qualified tradesperson.

Cabinet Installed by: _____ Phone: _____

Trade & license number: _____ Date: ____|____|____

Product name/description: _____ Purchase Date: ____|____|____

Product Warranty Number (found on door or drawer inside unit):



Adp

Architectural Designer Products Pty Ltd.
P.O. Box 1455, Unanderra NSW 2526 | ABN 34 073 064 721

 info@adpaustralia.com.au  www.adpaustralia.com.au  (02) 4271 2444   @adpaustralia